



SNAP-TITE® CULVERT LINING FIELD GUIDE FOR INSTALLATION, HANDLING, AND STORAGE



CULVERT-REHAB.COM
1-800-CULVERT
Q3 2023



HOW THIS GUIDE CAN HELP YOU

This guide was written for those who handle and install High Density Polyethylene (HDPE) Snap-Tite® Culvert Liners and accessory products like Hydro-Bell, Thread Liner, and oval Snap-Tite® pipe. This guide is not intended to provide design information, nor to assume the responsibility of the engineer (or other customer representative) in determining procedures for the specific job conditions to attain best performance of the liner.

Contractors, maintenance crews, engineers, superintendents, supervisors, and laying crews will find information to guide them. This manual will also be of help in selecting the needed materials to complete a culvert-lining project.

WARRANTY

ISCO Industries, Inc. warrants that our products are manufactured in accordance with the applicable material specifications, and are free from defects in workmanship and materials using our specifications as a standard. Every claim under this warranty shall be deemed waived unless in writing and received by ISCO industries, Inc. within thirty (30) days of the date the defect was discovered, or should have been discovered and within one (1) year of the date of the shipment of the product. ISCO Industries, Inc. makes no other representation or warranty of any kind, expressed or implied, in fact or in law, including without limitation, the warranty of merchantability or the warranty of fitness for a particular purpose, other than the limited warranty set forth above.

LIMITATION OF LIABILITY

ISCO Industries, Inc.'s liability is limited to the replacement of defective product, and ISCO Industries, Inc. shall have no liability whatsoever, except where damage or a claim results solely from breach of ISCO Industries, Inc.'s warranty. In no event shall ISCO Industries, Inc. be liable for any special, incidental consequential, or other damages whether or not similar to the proceeding, under any theory including negligence, breach of warranty, or strict liability.

TABLE OF CONTENTS

■	Receiving, Handling, and Storage.....	3-10
■	Supplies, Equipment, and Methods.....	11-20
■	Snap-Tite® Pipe Installation Steps.....	21-60
■	Nose Cone Construction.....	61-64
■	Oval Pipe Recommendation.....	65-68
■	Hydro-Bell Installation.....	69-76
■	Thread Liner Installation.....	77-79

For more information on Snap-Tite installation, visit <https://culvert-rehab.com/resources/installation/>.



DID YOU KNOW?

Snap-Tite® now meets the AASHTO standard M326. This is the **ONLY** standard for relining culverts. State Departments of Transportation, counties and municipalities are facing a critical problem, which has lead AASHTO (American Association of State Highway Transportation Officials) to create this standard. Culverts installed 40 to 50 years ago are failing at an alarming rate nationwide. Thousands of corrugated metal culverts are so significantly rusted that a danger of sink holes, road collapse or flooding exists. The solution: A Snap-Tite® Culvert Lining System.

RECEIVING, HANDLING, AND STORAGE

RECEIVING AND INSPECTING SNAP-TITE® SHIPMENTS

Upon arrival of each liner shipment, carefully inspect the liner. The liner was carefully loaded at the factory using methods acceptable to the carrier and it is their responsibility to deliver the pipe in good condition. **It is the responsibility of the receiver to make certain there has been no loss or damage in transit.**

The packing list, which accompanies each shipment, provides a complete list of all items included. Check the load against the packing list. The driver should also have a box of gaskets to deliver with the pipe. The delivering truck driver should ask the person receiving the shipment to sign the Bill of Lading, and acknowledge that the load was received in good condition. Note on the Bill of Lading any damage, missing packages, etc. at that time. Immediately report shipping problems such as damage, missing packages, document discrepancies, incorrect product, etc. File shipping claims within 7 days or as standard ISCO Terms and Conditions dictate (see <https://isco-pipe.com/terms-and-conditions/> for full details).

DAMAGE INSPECTIONS



Damage such as cuts, scrapes, gouges, tears, cracks, punctures, and the like may occur during handling and installation. Excessive damage could compromise pipeline performance. In many markets where pipelines are under pressure, the industry standard for HDPE pipelines is that damage should not exceed about 10% of the minimum wall thickness required for the pipeline's operating pressure or the minimum wall thickness required to meet structural design requirements.

If damage is not excessive, the shape of the damage may be a consideration. Sharp notches and cuts may be dressed smooth to blunt any notches. Blunt scrapes or gouges should not require attention. Minor surface abrasion from sliding on the ground or insertion into a casing should not be of concern.

In gravity flow and low pressure head applications like a Snap-Tite culvert liner, excessive damage like deep gouges, cuts or grooves may be evaluated based on site-specific criteria. Deeper gouges that do not penetrate to the pipe ID (and capable of withstanding grout pressures) may be considered acceptable, since a grouted liner carries very little, if any, structural load. When deemed necessary, repair methods are available to fill excessively deep cuts, abrasions, grooves, punctures or tears with new HDPE material.

LIFTING EQUIPMENT

Unloading and handling equipment must be appropriate for the type of packaging, must be in safe operating condition, and must have sufficient capacity (load rating) to safely lift and move the product as packaged. Equipment operators should be trained and, preferably, certified to operate the equipment.

When using a forklift, or forklift attachments on equipment such as articulated loaders or bucket loaders, lifting capacity must be adequate at the load center on the forks. Forklift equipment is rated for a maximum lifting capacity at a distance from the back of the forks. Reduce the lifting capacity if the weight-center of the load is farther out on the forks.



Before lifting or transporting the load, spread forks as wide apart as practical. Forks should extend completely under the load, using fork extensions if necessary, and the load should be as far back on the forks as possible. During transport, a load on forks that are too short or too close together, or a load too far out on the forks, may become unstable and pitch forward or to the side, and result in damage to the load or property, or hazards to persons.

Above the load lifting equipment such as cranes, extension boom cranes, and side boom tractors, should use wide fabric choker slings that are secured around the load or to lifting lugs on the component. Spreader bars should be used when lifting pipe or components longer than 20 feet. Before use, inspect slings and lifting equipment. Equipment with wear or damage that impairs function or load capacity should not be used.

HANDLING AND UNLOADING SNAP-TITE® PIPE

HDPE piping product transportation and handling is generally subject to governmental safety regulations such as OSHA in the United States or CCOSH in Canada. Persons transporting and handling HDPE piping products should be familiar with applicable governmental safety regulations. Additional HDPE pipe handling and transportation information is available in the Material Handling Guide from the Plastic Pipe Institute (www.plasticpipe.org). However, the responsibility for safe transport and handling rests primarily with persons that actually perform transport and handling activities.

Loading and unloading areas should be isolated and those not directly involved in the loading or unloading process should vacate the control area during material handling process. The contractor or owner should have written safety procedures to help prevent loss or injury on the work site. At no time shall workers walk on top of pipe loads, nor shall they place themselves beneath suspended loads. Wear appropriate personal protective equipment; hard hats, gloves, safety glasses, and steel-toed boots are recommended. Safety is the responsibility of the installing contractor or owner.

Observe safe handling and operating procedures. Although PE piping components are lightweight compared to similar components made of metal, concrete, clay, or other materials, larger components can be heavy.

Drivers contracted by ISCO Industries, Inc. to pick up and deliver HDPE to job sites are expected to adhere to ISCO standards regarding HDPE pipe handling, loading and unloading pipe. Handling and unloading equipment can be a wide variety of options, such as forklifts, cherry pickers, or front-end loaders with forks. However, the means by which pipe products are unloaded at the job site is the responsibility of the customer.

Give special attention while strapping and unstrapping loads. All personnel must be vigilant for sliding and rolling pipes while near trucks and lifting equipment. Take precautions to ensure that pipe is not dropped or damaged. Pipe, fittings, and special fabrications must not be pushed, rolled, or dumped off the truck.



The following are recommendations and guidelines to motor carriers for handling and unloading HDPE pipe at job sites.

- Park the truck on level ground with parking brake on and wheels chocked.
- Check the load to ensure that it has not shifted.
- Ensure that material handling, such as forklift, cherry picker, or front-end loaders with forks or spreader bar and lifting straps is available and adequate for the lift. Only properly trained personnel should operate unloading equipment. If you are using a forklift, have the forks spread as wide as possible for handling HDPE pipe.
- Be aware that HDPE pipe becomes very slippery to handle when wet, and avoid sharp and sudden movements when pipe is in contact with the forks.
- Do not move the truck if the straps are not secure around the pipe.
- Position the mechanical handling equipment before removing straps from the top unit loads.
- Do not stand on unsupported pipe! This can be extremely dangerous. Make sure the pipe is secure and supported by appropriate material handling equipment before mounting pipe to remove bands

- When cutting bands, cut only the bands securing the top tier to the tiers below. Do not stand on the banded pipe while cutting. Bands under tension can spring back when cut.
- Remove one unit at a time. If a strip board is across the top of a unit, remove it before lifting the pipe.
- When using a forklift to remove the pipe, the forks should enter the load slowly, taking care not to damage the pipe with the fork tips.
- If a forklift is not available, appropriately rated material-handling equipment such as a cherry picker or front-end loader with forks or spreader bar and lifting strap may be used.
- Do not use the forklift or other material handling equipment to push the load off the truck, as this is hazardous to unloading personnel and may damage the pipe and/or trailer.
- Personnel not involved in the unloading of the pipe should remain completely clear of the danger zone.
- Consider appropriate personal protective equipment as necessary such as gloves, hard hats, steel-toed footwear, and eye and hearing protection.
- **THINK SAFETY** and use caution at all times.



UNLOADING SITE/STORAGE

A suitable unloading site will be generally level and large enough for the carrier's truck, handling equipment and its movement, and for temporary load storage. General requirements for long-term storage are for the area to be of sufficient size to accommodate piping components, to allow room for handling equipment to get around them and to have a relatively smooth, flat, level surface free of stones, debris, or other material that could damage pipe or components, or interfere with handling. For some projects, several storage or staging sites along the right-of-way may be appropriate, while a single storage location may be suitable for another job. The site and its layout should provide protection against physical damage to components.



Pipe may be placed on 4-inch wide wooden dunnage or similar as shown in Figure 1-1. Middle support(s)/dunnage board(s) are not always required but may be useful as pipe diameters get smaller or as lengths increase. Using the boards will help maintain clearance for forklift forks or lifting slings. Using boards also helps create clearance for the pipe from water, where flotation of the plastic pipe could be at risk. Avoid storing Snap-Tite pipe in areas where flooding or washout could occur to avoid pipe movement.

Supports for the pipe should be a minimum distance of 3 feet away from each end. Supports that are closer to the ends increase the stress at the Snap-Tite male and female ends and can cause a crack to develop when the loading becomes excessive. Take care to insure no direct impacts or dropping the ends on the ground or against other surfaces as that can create the same stress event.

FIGURE 1-1

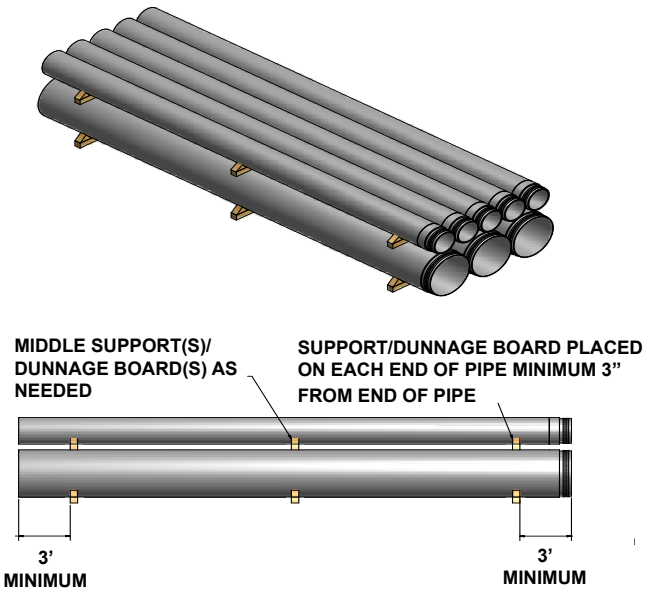

ENVIRONMENTAL: EXPOSURE TO UV AND COLD WEATHER

Snap-Tite and other HDPE piping products are protected against deterioration from exposure to ultraviolet (UV) light and weathering effects with antioxidants, and thermal and UV stabilizers. Black HDPE pipe and fittings contain at least 2% carbon black to limit the effects of UV attack. Black HDPE pipe and fittings are suitable for outdoor storage without covering or protection against UV exposure.

Temperatures near or below freezing will affect PE pipe by increasing stiffness and reducing resistance to impact damage. PE remains ductile at temperatures below -40°F (-40°C). In cold conditions, allow more time to conduct handling and installation procedures that bend and flex the pipe. Take extra care not to drop pipe or special fabrications, and to keep handling equipment and other things from making forceful impacts to the pipe.

Ice, snow, and rain are not harmful to the material, but unsure footing and traction require greater care and caution to prevent damage or injury. Inclement weather can make pipe surfaces especially slippery. Do not walk on pipe.

SUPPLIES, EQUIPMENT, AND METHODS

MATERIAL AND PROJECT CHECKLIST: SNAP-TITE® INSTALLATION

SNAP-TITE® LINER PIPE

- Snap-Tite Gaskets (Should be delivered with the pipe)
- Slikstyx or similar lubricant (vegetable spray)
(Should be delivered with the pipe)
- Rags to clean the pipe joints before connecting
- Mastic for oval pipe (Should be delivered with the pipe)

GROUTING AND VENTING OPERATIONS

- PVC pipe (24"-36" long) for Vents
- PVC pipe to pump grout (Quantity varies based on culvert length; see pages 28-30 for recommendations)
- PVC Glue/Cleaner
- PVC Male Threaded Adapters for connection to Grouting Equipment/hoses
- PVC End Caps to match PVC tubes or Oakum or rags to plug grout ports
** Normal Grout and Vent pipes are 2" Sch 40 PVC, but smaller annular spaces may dictate smaller diameter pipes

EQUIPMENT FOR JOINING AND MOVING PIPE

- 20-foot to 30-foot Chains
- Chain with Binders
- Chain Come-A-Long (See page 16 for sizing guidelines)
- Backhoe/Track hoe project dependent on site
- Choker cable (See page 20 for sizing assistance)
- 4x4 or 6x6 Post or plate material for pushing liner
- Pry bars/crow bars and/or long handled flat screwdrivers
- Chainsaw or reciprocating saw for trimming extra pipe, lumber, and nose cone (if required).
- Constructing a nose cone may require heavy-duty mechanics wire or steel wire rope to pull the sections together.

CONTINUED ON PAGE 12

CONTINUED MATERIAL AND PROJECT CHECKLIST: SNAP-TITE® INSTALLATION

MATERIALS USED FOR BLOCKING

- 2x4's or similar lumber for blocking material
- Screws (typically self-tapping -3" or longer) and/or ram set to bolt the 2"x4"s to the liner or host pipe, respectively
- Metal banding material with clamps if clamping blocking to liner pipe

BULKHEAD MATERIALS

- Ready-mix (see page 42 for mix design)
- Wheelbarrow or "portable mixer"
- Shovels
- Trowel
- Water
- Sealant like hydraulic water stop cement
- Road or geotextile fabric
- Alternate approaches include brick, oakum, chemical grout, or industrial grade closed-cell geotechnical polyurethane foams (requires spray foam application equipment)

GROUTING OPTIONS

- Grout pump and concrete/cement/grout
- Foaming machine (for cellular grouts) and foaming agent
- Fuel for equipment
- Water truck or other source
- Test cylinders when density checks are required

SUGGESTED CREW

- 4 laborers (which includes 2 people on the pipe joint for sizes 20" and up)
- 1 machine operator or winch for smaller sizes and lengths
- Radios
- Traffic control where necessary

TYPICAL/STANDARD METHOD OF PROCEDURE FOR RELINING CULVERTS

A DETAILED WORK PLAN SHOULD COVER MANY OF THESE ITEMS

1. Assessment and Inspection

- Host Pipe Cleaning (if required)
- Video Inspection (if required)

2. Sizing and Cleaning

- Verification of host pipe length, internal dimensions, and adequate clearance
- Blunt any sharp edges and remove debris, obstructions, and other hindrances to insertion

3. Methodology, Staging, and Job Prep

- Water control (coffer dams, bypass pumping) as needed
- Erosion Control, as required
- Determination of Push/Pull or combination
- Coordination of access, storage, and staging areas
- Grout Tube lengths and location map
- Vent Port location map
- Permits, as needed

4. Staging and Site Prep

- Installation of Blocking and Rails as needed
- Installation of Grout and Vent Tubes
- Liner Connection Areas

5. Pipe Installation

6. Bulkhead Installation

7. Grouting of Annular Space

- Grout mix density (including foaming instructions and equipment, when used)
- Grout lift plan and calculations in cases where multiple lifts are used
- Pressure monitoring of inlet and/or lowest location

8. Post Installation Acceptance

- Video Inspection (if required)
- Testing (if required)
- Waste removal, cleanup, and restoratio

COME-ALONG METHOD

Snap-Tite is so easy to install that most jobs can be completed with a backhoe, shovels, a come-along, and chains. Chain come-alongs are recommended over cable come-alongs for Snap-Tite installations since cable types can stretch and fray. Chains and come-alongs capacities are based on the size of liner to be installed. Standard chain come-alongs are available with load ratings of 1,000 to 5,000 lbs. of force. Verify the amount of force that the come-alongs are capable of applying before using them. For safety reasons, the chains normally are able to handle twice the load applied by each come-along.

Most chains have a working load. The working load is the normal rating for typical lifting applications. The strength at failure is usually four times the working load. When a chain is wrapped around a Snap-Tite liner and tightened with a chain binder, it is under tensile loading.



After a come-along is attached to a chain link, the link is subject to cross loading. A cross load occurs because the chain must wrap around the pipe to transfer the forces. As the cross load is increased, the angle of the chain around the liner changes. See diagram below:

FIGURE 2-1
CHAIN WRAP POSITION

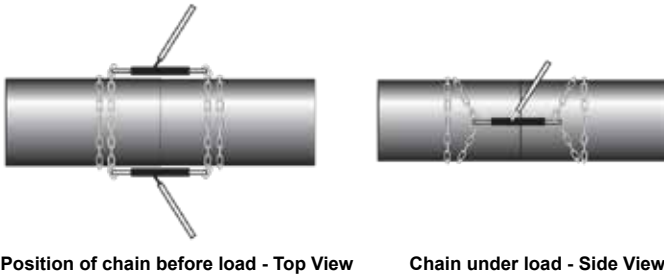

Chain manufacturers reduce the working load by 25% for cross loading. A chain with a standard rating of 6,000 lbs. is only rated for 4,500 lbs. in this application. If you have determined that you need 6,000 lbs. working load on the chain for a Snap-Tite Installation, then use an 8,000 lbs. working load rated chain.



Joining forces shown in Table 2-1 change with temperature, type of lubrication, male-female joint alignment, presence of debris, slope and time. Estimated forces are based upon the slow application of force with flat slope and lubricated joint. A slow application of force allows materials to stretch. Fast joining requires more force and energy because material does not immediately increase in size. More force will be required below 73 degrees F. Forces are estimated only! Forces shown in Table 2-1 are based on properly aligned 24-foot lengths. If different lengths are used, more or less force will be required.

TABLE 2-1

ESTIMATED FORCE TO JOIN SNAP-TITE® LINER					
SNAP-TITE® LINER OD (IN)	WEIGHT PER FT (LBS)	APPROX WEIGHT PER 24' (LBS)	ESTIMATED JOINING FORCE (LBS)	ESTIMATED TOTAL FORCE (LBS)	TYP MINIMUM LOAD RATING FOR EACH COME-ALONG (LBS)
10.75	4.8	118	500	618	1000
12.75	6.7	164	1000	1164	1000
14	8.1	198	1000	1198	1000
16	10.6	260	1000	1260	1000
18	13.4	328	1000	1328	1000
20	16.5	404	1000	1404	1000
22	20.0	490	1000	1490	1000
24	23.8	583	1500	2083	2000
26	27.9	684	1500	2184	2000
28	32.4	794	1500	2294	2000
30	37.2	911	1500	2411	2000
32	42.3	1036	2000	3036	3000
36	53.6	1313	3000	4313	3000
42	72.9	1786	3000	4786	3000
48	95.2	2332	3000	5332	3000
54	102.6	2514	3000	5514	4000
63	164.3	4025	4000	8025	5000

Apply the full load once the male and female joints come together straight on and part of the flat surface on both sides “catches.” The best joining procedure is to watch the joining process and make adjustments based on observations. When pipe movement requires more force than expected, look for a reason. If the joints do “catch”, rotation of the two liner sections or alignment with a pry bar may solve the problem. Sometimes changing the angle of attack or moving the pipe up and down or side to side will help start the connection.

If the male end is at a slight angle to the female and partially inserted, lower force is required to make the joints mate. Apply force from one come-along until liner bends slightly. Apply force slowly, this allows the female joint to expand.



CAUTION
Be careful when tightening a chain or cable!

Snap-Tite liners are not perfectly round. Take care to get alignment around the circumference of the Snap-Tite joint. Pry bars are sometimes used to help align the joints. Changing the position of come-along on the Snap-Tite liner may be helpful.

Be aware of the applied force. Allow only needed personnel near the come-along and chains. All others must remain at a safe distance from the chain. All personnel must use safety equipment during installation. Use gloves, hard hats, safety glasses and other personal protective equipment (PPE).

Chain wraps on the liner slip less than cable. Chains appear to be safer for this use. The mechanisms used in a come-along often fail when over stressed; be careful when using come-along!

Special safety equipment is required if there is moving water present, electrical lines are close to installation or if there are hazardous material in pipes. Check your job site and be prepared.

CHOKER METHOD

The Choker Method is another approach to installing Snap-Tite pipe. With this installation procedure, come-along and chains are not needed. The excavator/backhoe will do most of the work snapping the joints together.

To begin lining, slide the first piece of Snap-Tite pipe into the existing structure with at least two feet extending outside of the existing host pipe to allow room for connecting the joint. Before connecting the next pipe to the first one, install the gasket on the male end to ensure a watertight fit (see page 32).

Wrap a choker cable (minimum $\frac{3}{4}$ ") or chain around the pipe inserted in the culvert. Tighten the cable or chain down on the liner pipe as to keep the cable/chain from moving/ sliding and attach the excess cable/ chain to the



machine used. You can attach the cable/chain in the eyelet. Slowly back the machine up to fully tighten the choker against the liner.

The inserted piece of Snap-Tite is secured to prevent further movement into the host pipe, the operator will lower the mating piece of pipe into the ditch and the crew will vertically and horizontally align the male and female ends.

Line the joints up and slowly pull the pipe towards the 'choked' pipe. The tapered end of the male joint will line up with the beveled end. Once the alignment is equal around the pipe, the operator will slowly apply pressure by pulling the pipe he had held with his bucket and a choker cable/chain. The operator will slowly rock the joint left to right, 'walking' the joint together.



Once the spigot joint is connected, the backhoe can push the remainder of the pipe further into the host pipe. Repeat this process until the liner is installed completely through the host pipe.

CHOKER METHOD DETAILS

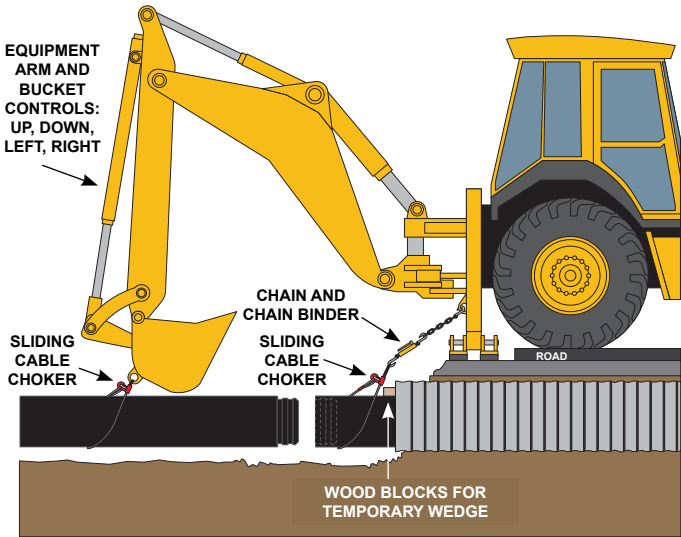

TYPICAL CABLE LENGTHS AND DIAMETER	
12" - 18" Liner Pipe	5/8" Cable x 5' Long
20" - 24" Liner Pipe	5/8" Cable x 8' Long
30" Liner Pipe	5/8" Cable x 10' Long
36" Liner Pipe	5/8" Cable x 12' Long
48" Liner Pipe	5/8" Cable x 16' Long
48" and Greater	3/4" Cable x "X" Long

CHOKER CABLE FORMULA

OD of Liner Pipe x 3.14 ÷ 12 = Feet Around Pipe
Add Length Needed for Tail-End

Example:

30" Liner Pipe X 3.14 = 94.2 ÷ 12 = 7.85 + 4 = 12 ft Cable

In this example, a tail length of just over 4' was assumed adequate.

SNAP-TITE® PIPE INSTALLATION STEPS

EXAMPLES OF FAILING CORRUGATED METAL AND CONCRETE CULVERTS



Invert rusting and voids underneath



Complete loss of pipe bottom/invert

**EXAMPLES OF FAILING CORRUGATED METAL
AND CONCRETE CULVERTS**



Misaligned joint with voids



Loss of bottom from pipe exit

STEP 1: PREPARE THE EXISTING CULVERT

- Inspect the culvert to ensure no obstructions prevent insertion of the liner. Flush and/or clean the existing culvert.

Prior to lining, check each culvert for access. Evaluate the safety of the installation area. Clear an area near the culvert for access. There must be an open area equal to the liner section on at least one end of the culvert.

Inspect vertical and horizontal alignment of host pipe to ensure clearance for the liner pipe. Take measurements at various locations throughout the host culvert to verify the smallest ID, as well as total length. Consider a survey for complex installations.

Remove dirt and rocks from the culvert. If a culvert requires cleaning, a water truck or jet cleaner may be needed. After cleaning and preparing the culvert for lining, make sure there is nothing protruding from the culvert that will damage the liner.



Evaluate the invert and channel bed conditions of the culvert. If there are voids around the old culvert, consider filing these voids prior to lining. If a high flow grout is used, these voids will often be filled as the liner is grouted. However, the amount of grout required to complete the job can become high and unknown.



It is possible to install Snap-Tite culvert liners when water is present. Installation during low flow conditions presents low safety risk. Fast flowing water can create a safety hazard. Use good judgement if water is present. Grouting with standard cement grout can be done when water is present. Special precautions may be required when grouting with cellular grout and water is present. Consult your grout supplier if water is present.

STEP 2: ADD BLOCKING TO EXISTING/HOST CULVERT

If needed, attach wooden “blocks” to the top of the host pipe in order to keep the Snap-Tite pipe from rising up.

Controlling the location of the liner inside the culvert is important. Flotation of the liner is of concern when grouting around the liner or there is ground water present. As grout density increases, upward buoyant forces increase. A liner is like a boat - it displaces the grout and if the liner weighs less than the grout, the liner floats. To prevent flotation, use blocks or skids around the pipe to maintain grade of the Snap-Tite Culvert Liners.

Blocking usually is not required for smaller culvert sizes, when the annular space is less than 4”. As the culvert size increases and the liner size decreases, the need for blocking to hold grade becomes more important. Use blocking at the top of the host to keep the liner close to the bottom of the culvert. Blocking on the bottom of the existing pipe is not always necessary, but it does help facilitate insertion by helping slide past corrugations, damaged inverts, and separated or misaligned joints.

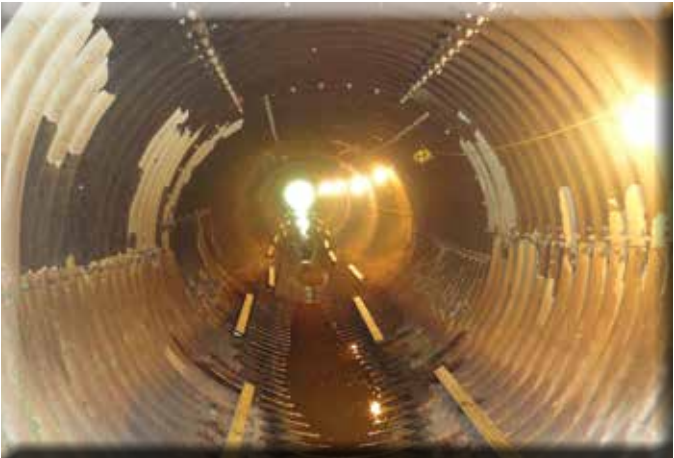

Figure 3-1 on pages 28-29 shows typical blocking of Snap-Tite® Culvert Liner. Blocks or skids are typically installed in a staggered pattern. Spaces are left between the blocks or skids allow grout to flow under and around the liner. Beveling skids and blocking may help facilitate easier installation of liner pipe.

Install blocks in the top 120 degrees of the culvert beginning at 4 feet from the inlet and outlet to allow for installation of the bulkhead. For culverts 36" in diameter or larger, blocks are attached to the old culvert. The first blocks are often installed at 11 and 1 o'clock positions, with a space of four to eight feet between the next set of blocks, based on liner size. Blocks are usually four to eight feet in length. The thickness is determined by the difference in the ID of the culvert and the liner.



The upper skids must have structural strength adequate to resist the buoyant force created as the liner is grouted in place. Wood and solid plastic will work. Styrofoam does not have adequate compressive strength to work for many liner sizes.

Filling the liner with water is one way to reduce flotation. Since water weight is 62.4 lbs. per cubic foot, if the grout has a higher density, filling the liner with water may not solve the problem. Filling the liner with water is usually not recommended, and can prove to be difficult in many cases.

STEP 3: HANG GROUT TUBES IN EXISTING/HOST CULVERT

If access is large enough, install different lengths of PVC pipe that will deliver the grout flow and also release air.

Before the liner pipe is inserted into the host pipe, use pipe straps and 3" Self Tap Screws to hang grout and vent tubes at approximately 4' spacing. Hang grout tubes between the blocking to protect it from damage during pipe liner installation. Use wire and screws in lieu of clamps if necessary.



TABLE 3-1

TYPICAL GUIDE FOR GROUT AND VENT TUBE PLACEMENT SITE CONDITIONS MAY VARY		
CULVERT LENGTH	AIR VENTS INLET SIDE*	AIR VENTS OUTLET SIDE*
50' or less	12, 3, 9 O'Clock	12, 3, 9 O'Clock
50' - 100'	12, 3, 9 O'Clock	12, 3, 9 O'Clock
100' - 150'	12, 3, 9 O'Clock	12, 3, 9 O'Clock
150' - 200'	12, 3, 9 O'Clock	12, 3, 9 O'Clock
200' - 250'	12, 3, 9 O'Clock	12, 3, 9 O'Clock
250' - 300'	12, 3, 5, 7, 9 O'Clock	12, 3, 5, 7, 9 O'Clock
300' - 350'	12, 3, 5, 7, 9 O'Clock	12, 3, 5, 7, 9 O'Clock
350' - 400'	12, 3, 5, 7, 9 O'Clock	12, 3, 5, 7, 9 O'Clock

*All Air Vents are typically 2" Sch 40 PVC Pipe 3' in length.
For Culverts over 400' in Length, consult a Snap-Tite® Sales Rep.

Refer to Figure 3-1 on the next page for graphic image

TYPICAL GUIDE FOR GROUT AND VENT TUBE PLACEMENT SITE CONDITIONS MAY VARY		
CULVERT LENGTH	GROUT TUBE(S) INLET SIDE (ALL NEAR 12 O'CLOCK)**	GROUT TUBE(S) OUTLET SIDE (ALL NEAR 12 O'CLOCK)**
50' or less	1 at 10' long ■	1 at 10' long ▲
50' - 100'	1 at 20' long ■	1 at 20' long ▲
100' - 150'	1 at 30' long ■	1 at 30' long ■
150' - 200'	1 at 30' long ■ 1 at 60' long ■ 1 at 120' long ▲	1 at 30' long ▲ 1 at 60' long ▲
200' - 250'	1 at 30' long ■ 1 at 60' long ■ 1 at 120' long ■	1 at 30' long ▲ 1 at 60' long ▲ 1 at 120' long ▲
250' - 300'	1 at 30' long ■ 1 at 60' long ■ 1 at 120' long ■ 1 at 150' long ▲	1 at 30' long ■ 1 at 60' long ▲ 1 at 120' long ▲ 1 at 150' long ▲
300' - 350'	1 at 30' long ■ 1 at 60' long ■ 1 at 120' long ■ 1 at 150' long ■ 1 at 200' long ▲	1 at 30' long ■ 1 at 60' long ▲ 1 at 120' long ▲ 1 at 150' long ▲
350' - 400'	1 at 30' long ■ 1 at 60' long ■ 1 at 120' long ■ 1 at 150' long ■ 1 at 200' long ■ 1 at 300' long ▲	1 at 30' long ■ 1 at 60' long ■ 1 at 120' long ▲ 1 at 150' long ▲

**All Grout Tubes are typically 2" Sch 40 PVC Pipe

■ Recommended

▲ Suggested as extra tubes for challenging installations

PLAN VIEW OF CULVERT LINER INSTALLATION WITH FEED TUBES

FIGURE 3-1
THIS IS ONLY AN EXAMPLE, DESIGN MAY VARY

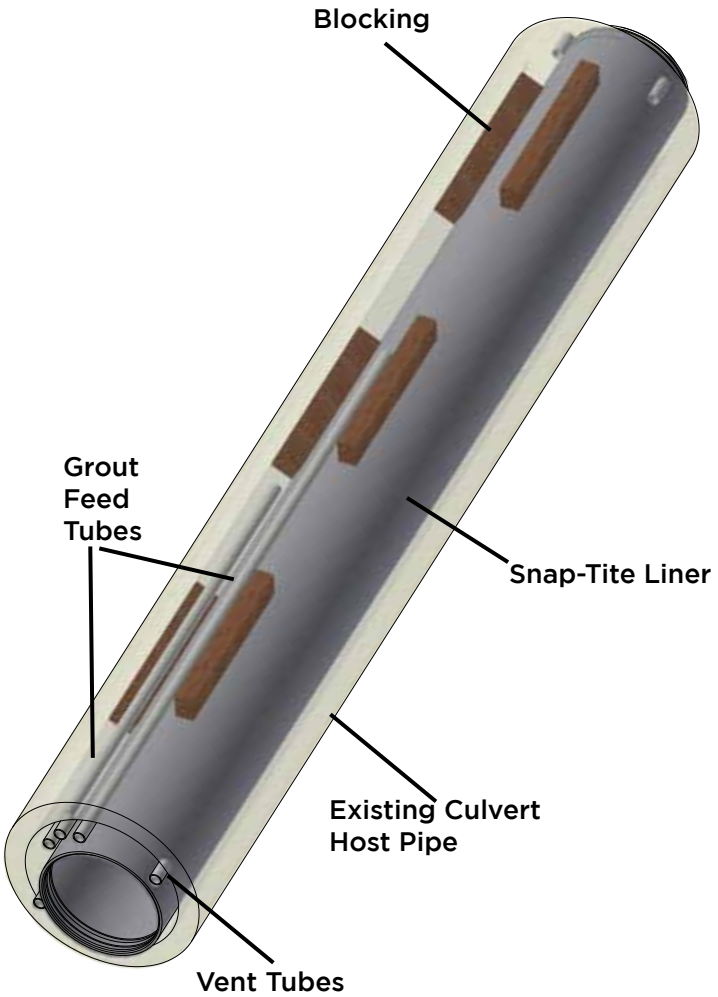



THE SNAP-TITE® SOLUTION

Railroad companies choose to use Snap-Tite because the Snap-Tite system does not require any special training or special equipment, so the railroad's maintenance crew can handle relining the failing culvert.

In addition, the Snap-Tite culvert lining system is a no-dig solution for culvert repair, meaning there is no need for major excavations or disruptions to the rail or road traffic during construction.

STEP 4: INSERT ONE END OF SNAP-TITE® CULVERT LINER INTO EXISTING CULVERT

Lower the first piece of Snap-Tite HDPE into position and insert into the host pipe.

To begin lining, slide the first piece of Snap-Tite pipe into the existing structure with at least two feet extending outside of the existing host pipe to allow room for connecting the joint. Point the male end of the Snap-Tite downstream, towards the outlet end. When required to assist installation, it may be necessary to create a “nose cone” by cutting the ends of the pipe. See directions beginning on page 61.



NOTE: A Hydro-Bell is designed to insert into the female end at the inlet end if these directions are followed and male end are pointed downstream (towards the outlet).

STEP 5:
**POSITION THE NEXT SECTION OF SNAP-TITE®
CULVERT LINER WITH PROPER ALIGNMENT**

Lower the second piece of pipe into position and line with the first piece. Place the opposing end of a second section against the exposed end of the first section. The two sections must be in alignment and have the same slope.



Snap-Tite liners are not perfectly round. Due to the flexible nature of HDPE pipe, the male and female ends may not match up as perfectly round shapes. Some ovality may exist. To help with the joining process, this would be a good time to rotate the next section of pipe so that the best fit for alignment is achieved. Using boards, hydraulic rams/jacks, Porta-power, or other methods to reround the pipe may help achieve a better match.



Take care to get alignment around the circumference of the Snap-Tite joint. Pry bars are sometimes used to help align the joints. Changing the position of come-along on the Snap-Tite liner may be helpful.

STEP 6: INSTALL GASKET ON MALE END

Place a gasket on the male end of the liner in the first groove (top picture). Apply lubricant evenly to the gasket (bottom picture).

A gasket should be supplied with Snap-Tite pipe. Install the gasket in the first groove from the end on the male end to help make a watertight seal. Check the fit of the gasket around the liner. Apply lubricant to the entire circumference of the gasket. Apply the lubricant evenly to reduce the chance of a torn or rolled gasket.



STEP 7:
ATTACH THE CHAINS AND COME-ALONGS
OR CABLE COKER



Use come-a-longs and chains (placed approximately 180 degrees apart on each side) and pressure from the excavator to “snap” the two pieces of pipe together. Double-wrap the chains approximately two feet from the coupling end and tighten with binders. Attach one come-along on each side of joint, 180 degrees apart.



STEP 8: SNAP THE LINER TOGETHER

Align the ends of the male bevel inside the female bevel. Use a pry bar or move the come-along to different positions on liner if pipe is out of round to improve alignment.



Pull the ends together slowly, forcing the female end to expand and allow the male end to move into the female end. Apply force slowly and make observations. Apply force to one side until liner slightly deflects, then apply force on other side. Look for the female side to increase in OD as force is applied. Listen for two distinct popping sounds as they “snap” together



If chain or come-along appears to be overstressed, stop operation! Quickly move away from the chain! When lands and grooves are aligned, the couplings will “snap” and lock together. Allow time for this to occur.



If operation is stopped, check alignment. Often poor alignment or a stone or dirt in the grooves of the male/female ends may cause the need for additional pressure. Rotation of the liner will change alignment. Clean out the joint if needed.



STEP 9:
PUSH/PULL JOINED LINERS INTO CULVERT AND
REPEAT UNTIL COMPLETELY LINED



Remove chains or chokers and push or pull the joined liners into culvert. In some applications, it may be necessary to both push and pull the liner to achieve insertion in the host.



Repeat steps 5-9. Snap each new piece of pipe onto the proceeding pipe and push into the culvert, leaving enough pipe protruding from the culvert to join with the next length of liner.



Repeat the process until connected sections of Snap-Tite line the entire length of the culvert. Snap-Tite liner pipe will expand and contact therefore industry standard practice requires that a minimum of six inches of liner pipe to extend beyond the inlet and outlet ends of the host pipe.

JOINT INTEGRITY

Carefully following the procedures set out in this Field Guide will reduce the chance of leaks between joints. Dirt, sand, or rock in the joint area may affect the integrity of the joint and create leaks. Placement of a joint where the existing culvert bends or deflects, or where the joint is otherwise stressed may increase the chance of leakage. In these situations, shorter lengths of Snap-Tite Culvert Liner may sometimes be used to avoid the problem.

After the joints are complete, it is normal for a slight separation or gap at the joint due to the flexible nature of the pipe. The size of the gap may vary due to the thermally induced expansion and contraction experience by the pipe material during the course of installation. As liner sizes increase, a gap or separation up to 1" may be observed. The gasketed joint will prevent any grout penetration from outside and the gap should stabilize and not vary once the grout has cured.



STEP 10: SEAL THE CULVERT ENDS

Once the entire culvert is lined, build bulkheads or end-seals on each end of the culvert.

Before grouting, seal the annular space at both ends of the liner and culvert. Since most grouts flow like water, much of the grout will be lost if the old culvert is not sealed. Bulkheads are the best way to seal the annular space and prevent grout from escaping. Bulkheads must have sufficient strength to sustain hydrostatic pressure during annular grout placement.



Make an end seal for the annular space at a distance of one to two feet at each end using an appropriate mix. The end seal in the annulus can be made by using various materials. A relatively dry cement grout is used in most situations. Bricks, bags of cement, oakum, and chemical grout have also been used successfully.

FIGURE 3-2
TYPICAL BULKHEAD CONFIGURATION

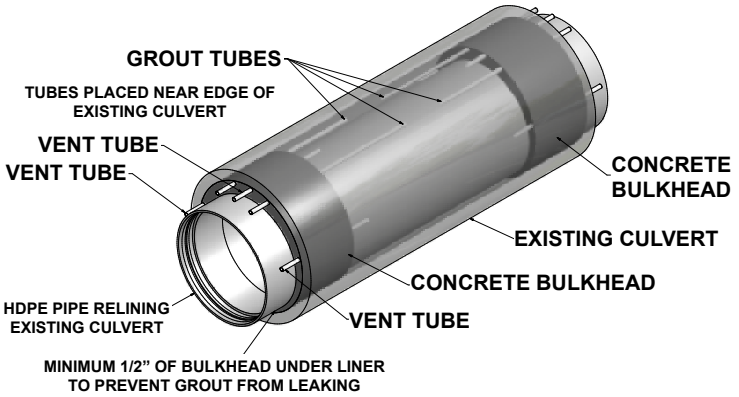

While sealing the annular space, install vents to allow air to escape. Usually vents are installed at both ends of the culvert.

CHECKLIST FOR BEST PRACTICES FOR BULKHEAD BUILDING

- ✓ Proper bulkheads at both ends with vent tubes and grout tube(s) are required before grouting can begin.
- ✓ Allow the bulkheads to cure for a minimum of 24 hours before grouting.
- ✓ Once the bulkhead mix is on site and ready to be packed into the culvert, start by packing bulkhead mix at least ½" thick and a minimum of 2' deep around the bottom of the liner to prevent grout mix from leaking out during the grouting process.
- ✓ Place vent tubes at the highest point (12 O'Clock) on both ends of the culvert.
- ✓ Pay special attention to the areas around the outside of the old culvert and if there is any deterioration or holes, pack those areas with the bulkhead mix.



TYPICAL BULKHEAD MIX DESIGN (PRODUCES 1 CUBIC YARD)

- 2400 pounds of sand
- 752 pounds of cement or 8 bags
- 225 pounds of type C fly ash
- 25 gallon water
- Retarder depending on temperature outside
- Pack Bulkhead 2' deep on both ends

FIGURE 3-3 END VIEW OF BULKHEAD

Vent tubes places at 12, 3, and 9 o'clock
Grout tubes places on both sides of top vent tube. All tubes near edge of existing culvert.

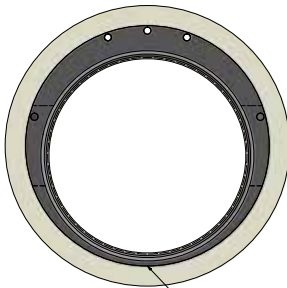

Minimum 1/2" below liner for bulkhead to prevent grout mix from leaking

STEP 11: GROUT THE ANNULAR SPACE

Grouting the annular space between the existing culvert and the liner is recommended. Filling the annular space with grout provides additional structural support and prevents point loading.

After placing the Snap-Tite® Culvert Liner in the existing culvert, remove any water above the invert whenever possible. Keep water out of the annular space during the grouting process since it can interfere with the injection and curing of the grout.

The Snap-Tite Design Guide provides additional information on grouting but the major points for an installer to be aware are these:

- Due to the strength of the liner, grouting pressures should be limited to 2 psi. Groundwater and hydrostatic pressures at the liner may not be the same as measured at the grout pump.
- Cellular grouts are preferred due to flowability and low pressures
- Flowable fills can be used but will require more care and material
- Consider grouting in lifts in certain situations (See page 50-51 for more information)

GROUTING CONSIDERATIONS

Grout can be placed into the annular space in between a Snap-Tite® Culvert Liner and a culvert in many different ways. Evaluate each job based on the existing conditions. Some of these factors are:

- Size of liner and size of existing host culvert
- Elevation changes from upstream end to downstream
- Grout Density
- Access to injection point or points
- Limitations on injection points
- Length of culvert
- Cost
- Presence of ground water

THE GROUTING PROCESS

When installing grout, take your time. Watch the liner and pumping pressures. If deflection of the liners occurs, reduce pressure and stop pumping for a short time. Many problems occur when the process is rushed or someone gets in a hurry.

The grout may cause the pipe to float due to buoyant forces and open the joints if too much pressure is applied. Movement and excessive pressure may cause the joint to leak. Halt the grouting process if the joint appears to be compromised. Check all grouting pressures and the shape of the liner pipe before continuing or wait for the grout to set up before resuming.

For culvert/liner lengths of less than fifty feet, grout often can be placed by pouring the grout into place with grout holes. When the grade is relatively flat, this is a good approach. Pressure on the liner is usually minimal.

When it is possible to bore multiple openings in the existing host culvert (above the liner), grout can easily be poured in place at regular intervals (often 20-foot spacing). For culverts under roadways, this will usually require stopping traffic at least in one lane and repair of the borehole. Again, the pressure on the liner is minimal, but there may be other factors to consider.

Grouting starts at one end of the line and proceeds to the other end. Grout will become visible at each succeeding grout hole. Grouting will continue until each hole is filled with grout. Air must be pushed out of the annular space. Take your time; let air work its way out to prevent voids in the annular space. Voids reduce the strength of the system. Deflection and buckling are more likely in unreinforced liner areas. When void areas are detected, a hole can be drilled and grout injected with a wand.

Grout is normally installed from the upstream end of the culvert. When the culvert has a flat grade, grouting from the downstream end can be performed with few issues. As the elevation changes from one end of the culvert to the other, it is easier to install grout by filling from the upstream end.

When space allows, filling the annular space with grout from the inside of the liner is possible, but will often require grout ports be installed in the liner pipe wall. This method can also assist when the slope/curvature of the host pipe ceiling varies extensively across the length of the culvert as installing grout tubes would be challenging in this situation.

Grouting from the downstream end may be considered to assist in venting air and water. However, it often can create some challenges with grouting pressures and clogged grout ports. Grouting from the upstream end is preferred unless there are issues with access or space constraints.

A standpipe might be used to fill the annular space between the host pipe/culvert and the inserted liner. If the old pipe/culvert is well below the roadway, a standpipe or extension hose is a good way to reach the fill pipe(s). However, once the air is fully vented or cannot escape, pressure on the liner can build up and apply a significant force at the bottom of the liner.

If the grout is heavier than water (true in all cases except cellular grouts), the head pressure will be even higher. If the liner is grouted in place in one pour or lift, this force of water or grout can collapse the liner when exceeding the allowable grout pressure of 2 psi. In this application, grouting in lifts is usually the best application method.



When the elevation change along a culvert is great, grout falls to the bottom of the annular space and fills the lowest grout tubes and vent ports. When the grout hardens, the fill pipe can no longer be used. Multiple fill pipes can be used to fill the annular space. Each fill pipe will be used to fill to a required elevation for that lift. Each fill pipe will usually be of a different length and elevation in the annular space. Remember, a pipe on a relatively flat pitch will receive grout much differently than a pipe with a 10% slope.

Vents are set at elevations required for each lift. Vent ports allow air to escape the annular space and can be used to verify grout levels during grouting.

The term “lifts” indicates that only a portion of the grout is poured into the annular space at one time. By placing only a portion of the grout around the pipe, the collapse force on the liner pipe is minimized. Grouting in lifts means that only a part of the grout is flowed around the liner and allowed to reach initial set or cure.

Allow the previous lift to set before beginning the next lift. By allowing each lift to harden before adding the next lift, the liner receives additional support and reduces the likelihood of collapse. The highest forces occur below the pipe's springline, so take your time during the first and second lifts. See Figure 3-4 below.

FIGURE 3-4
GROUTING IN LIFTS

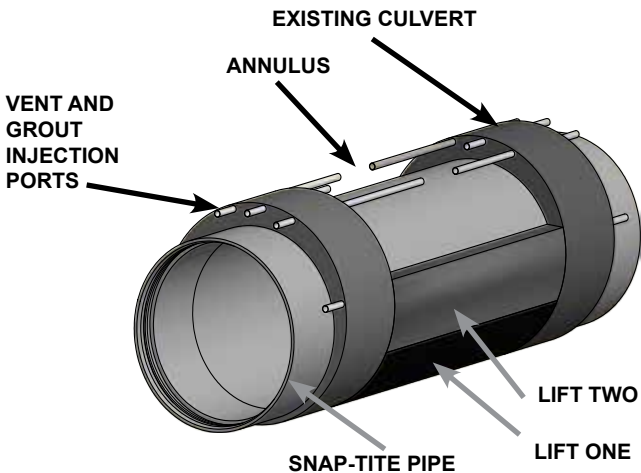

Lifts may be necessary when there is a large change in elevation between culvert inlet and outlet resulting in higher pressures on the liner or bulkhead. As pipe size and/or slope increases, it becomes more important to evaluate hydrostatic loading and potentially place the grout in lifts. When there is several feet of uncured grout over the liner, the weight of the grout can be significant. Grouting in lifts is usually the best way to grout long runs with higher density grout formulations.

When grouting with multiple lifts, measure the amount of grout added per lift. Fill the annular space with the calculated amount of grout. Fill each lift with this calculated amount of grout. More grout will be required if there is a void around the old culvert. If the existing culvert is partially collapsed, less grout may be required.



GROUT TYPES

Information on grout mixes are provided below as a guide only. Consult suppliers of grout additives or grouting contractors for additional information, including alternate or custom formulations.

The basic requirements for grout selection are flow and strength. You must be able place or transport the grout into the annular space with minimum pressure and it must have adequate strength to support the liner and reinforce the soil around the old culvert.

Cellular grouts have wetting agents that allow for the inclusion of air, which results in a mixture that is lighter than water. The addition of the air will reduce the amount of cement mixture that will be needed to fill the annular space. Cellular grouts are usually the only type of grout that will flow long distances under low pressure conditions. Cellular grout can solve issues related to the difficulties of pumping or flowing long distances with less than 2 psi of pressure.

Cellular grout can also reduce flotation forces. Select a cellular grout with a density between 20-40 pcf and a compressive strength in the range of 150 psi minimum compressive strength unless the project requires something greater. This compressive strength will adequately support the Snap-Tite® Culvert Liner in most situations. Have a structural engineer make evaluations or recommendations for your specific application.

Flowable fill, with densities greater than 100 pcf, has been used for many years to grout Snap-Tite® Culvert Liners in place. As the density increases, greater care is needed when placing it.

Increasing the size of the aggregate in the grout makes high compressive strength grout. As the aggregate size increases, the pressure and velocity required to keep aggregates from settling out becomes higher. Bridging occurs when sand or other aggregates deposit in one area causing a blockage. This occurs quickly if grout flow is stopped during placement while waiting for the next mix truck to deliver. Increasing the grout pressure to clear this blockage is not recommended. The increased pressure could cause the liner to buckle or collapse.

The following tables offer mix designs for grouting the annular space between the liner and the old culvert. These mixes are provided as guides only. Aggregates vary greatly. Consult your local ready mix supplier for their recommendations for grout and flowable fill. The mix designs are for one cubic yard of concrete.

The table below for low Density Cellular Concrete (LDCC) uses Aerix Industries Aerlite-iX foam at a 2.0 pcf foam density and 1:60 foam dilution ratio. Other grout mixes (30-90 pcf densities) are available upon request. If you are using a different foam concentrate, please contact Aerix Industries Technical Department.

TABLE 3-2

MIX DENSITY (LB/FT ³)	CEMENT (LB)	WATER (GAL)	FOAM (LB)		FOAMING INSTRUCTIONS		
					WATER (GAL)	AERLITE-IX FOAM CONCENTRATE (OZ)	FOAMING TIMES (FOR 1 YD ³)
40 pcf	687	36	17.8	←	4.25	8.8	54 secs
55 pcf	958	60	14	←	3.3	6.9	42 secs
70 pcf	1230	76.5	10.5	←	2.5	5.2	32 secs

***Mix produces one cubic yard of Low Density Cellular Concrete (LDCC)**

****Foaming times are based on Aerix Industries T80-20 foam generator producing foam at 20 cfm. When using a different foam generator please contact Aerix Industries Technical Department.**

The Federal Highway Administration provides some sample mix designs in Chapter 5 of the publication Fly Ash Facts for Engineers. While these mix formulations are not specifically designed for culvert applications, the project engineer can determine the suitability. The mix designs are for one cubic yard of flowable fill.

TABLE 3-3

FHWA MIX	DENSITY (LB/FT ³)	CEMENT (LB)	FLY ASH (LB)	SAND (LB)	WATER (GAL)	AIR CONTENT %
Table 5-1	96.3 pcf	104	2,080	0	50	n/a
Table 5-2	129.6 pcf	100	300	2600	60	n/a
Table 5-3	110.8 pcf	50	350	2300	35	20-24

Table 5-1. High fly ash content mix

Table 5-2. Low fly ash content mix

Table 5-3. Flowable fill mix with high air content.

Additionally, Aerix Industries provides Controlled Low Strength Material (CLSM) flowable fill produced using AERFLOW. AERFLOW is a synthetic anionic liquid concentrate specially formulated to produce a stable, voluminous micro-bubbled foam. Admixtures like AERFLOW are used in direct combination with sand/cement slurries for the production of CLSM concrete. This material, also known as flowable fill, is engineered with densities ranging from 100 to 115 pcf. The mix designs are for one cubic yard of concrete. Other admixture suppliers may have different recommendations including amounts of admixture amounts.

TABLE 3-4

MIX**	CLSM DENSITY (LB/FT ³)	CEMENT (LB)	FLY ASH (LB)	SAND C-33 (LB)	WATER (GAL)	AERFLOW (PER YD ³)*
CF1	113.5 pcf	125-150	0	2600	30	3 oz.
CF2	115 pcf	75-100	0	2500	32	3 oz.
CF3	112 pcf	50	250	2500	34	3 oz.
CF4	110 pcf	50	350	2300	35	3 oz.

*AERFLOW is added at the job site and mixed for 5 minutes at mixing speed

** Foam Enhancement changes a 1.5" (+/-) slump to 7"-9" slump

Note that CF4 matches the FHWA Table 5-3 mix and provides the amount of AERFLOW to create 20%-24% air content.



Below is a chart to help the installer identify the amount of pressure that is possible based on the density of the grout selected and the depth of height.

TABLE 3-5

GROUTING PRESSURE IN PSI BASED ON DENSITY AND DEPTH													
Lift Height (ft)	GROUT DENSITY (PCF)												
	← TYPICAL CELLULAR GROUT DENSITY RANGE →												
	30	35	40	45	50	55	60	65	70	75	80	85	90
1	0.21	0.24	0.28	0.31	0.35	0.38	0.42	0.45	0.49	0.52	0.56	0.59	0.62
2	0.42	0.49	0.56	0.62	0.69	0.76	0.83	0.90	0.97	1.04	1.11	1.18	1.25
3	0.62	0.73	0.83	0.94	1.04	1.15	1.25	1.35	1.46	1.56	1.67	1.77	1.87
4	0.83	0.97	1.11	1.25	1.39	1.53	1.67	1.81	1.94	2.08	2.22	2.36	2.50
5	1.04	1.22	1.39	1.56	1.74	1.91	2.08	2.26	2.43	2.60	2.78	2.95	3.12
6	1.25	1.46	1.67	1.87	2.08	2.29	2.50	2.71	2.92	3.12	3.33	3.54	3.75
7	1.46	1.70	1.94	2.19	2.43	2.67	2.92	3.16	3.40	3.65	3.89	4.13	4.37
8	1.67	1.94	2.22	2.50	2.78	3.06	3.33	3.61	3.89	4.17	4.44	4.72	5.00
9	1.87	2.19	2.50	2.81	3.12	3.44	3.75	4.06	4.37	4.69	5.00	5.31	5.62
10	2.08	2.43	2.78	3.12	3.47	3.82	4.17	4.51	4.86	5.21	5.56	5.90	6.25
11	2.29	2.67	3.06	3.44	3.82	4.20	4.58	4.96	5.35	5.73	6.11	6.49	6.87
12	2.50	2.92	3.33	3.75	4.17	4.58	5.00	5.42	5.83	6.25	6.67	7.08	7.50
13	2.71	3.16	3.61	4.06	4.51	4.96	5.42	5.87	6.32	6.77	7.22	7.67	8.12
14	2.92	3.40	3.89	4.37	4.86	5.35	5.83	6.32	6.81	7.29	7.78	8.26	8.75
15	3.12	3.65	4.17	4.69	5.21	5.73	6.25	6.77	7.29	7.81	8.33	8.85	9.37

62.4 PCF= Unit weight of water

- Yellow: Grouting pressure below 2:1 safety factor
- Orange: Grouting pressure exceeds collapse pressure

GROUTING PRESSURE IN PSI BASED ON DENSITY AND DEPTH									
GROUT DENSITY (PCF)									Lift Height (ft)
← TYP FOR REDUCED → DENSITY FLOWABLE FILL					← TYPICAL DENSITIES → FOR FLOWABLE FILL				
95	100	105	110	115	120	125	130	135	
0.66	0.69	0.73	0.76	0.80	0.83	0.87	0.90	0.94	1
1.32	1.39	1.46	1.53	1.60	1.67	1.74	1.81	1.87	2
1.98	2.08	2.19	2.29	2.40	2.50	2.60	2.71	2.81	3
2.64	2.78	2.92	3.06	3.19	3.33	3.47	3.61	3.75	4
3.30	3.47	3.65	3.82	3.99	4.17	4.34	4.51	4.69	5
3.96	4.17	4.37	4.58	4.79	5.00	5.21	5.42	5.62	6
4.62	4.86	5.10	5.35	5.59	5.83	6.08	6.32	6.56	7
5.28	5.56	5.83	6.11	6.39	6.67	6.94	7.22	7.50	8
5.94	6.25	6.56	6.87	7.19	7.50	7.81	8.12	8.44	9
6.60	6.94	7.29	7.64	7.99	8.33	8.68	9.03	9.37	10
7.26	7.64	8.02	8.40	8.78	9.17	9.55	9.93	10.31	11
7.92	8.33	8.75	12.22	9.58	10.00	10.42	10.83	11.25	12
8.58	9.03	9.48	9.93	10.38	10.83	11.28	11.74	12.19	13
9.24	9.72	10.21	10.69	11.18	11.67	12.15	12.64	13.12	14
9.90	10.42	10.94	11.46	11.98	12.50	13.02	13.54	14.06	15

TABLE 3-6

GROUTING VOLUME OF ANNULAR SPACE			
HOST CULVERT SIZE (IN)	SNAP-TITE® LINER OD (IN)	CU FT/ FT OF CULVERT	CU YD/ 10 FT OF CULVERT
12	10.75	0.16	0.06
15	12.75	0.34	0.13
18	14	0.70	0.26
18	16	0.37	0.14
21	16	1.01	0.37
21	18	0.64	0.24
24	18	1.37	0.51
24	20	0.96	0.36
24	22	0.50	0.19
27	22	1.34	0.49
27	24	0.83	0.31
30	24	1.77	0.65
30	26	1.22	0.45
36	28	2.79	1.03
36	30	2.16	0.80
36	32	1.48	0.55
42	32	4.04	1.49
42	36	2.55	0.95
48	42	2.95	1.09
54	42	6.28	2.33
54	48	3.34	1.24
60	48	7.07	2.62
60	54	3.73	1.38
66	54	7.85	2.91
66	63	2.11	0.78
72	63	6.63	2.45

NOTE: Minimum estimate grout volume based on calculated annular space. Additional volume may be required to fill any voids.

**EXAMPLES OF A REHABILITATED CULVERTS
AFTER COMPLETING STEPS 1-11**



**EXAMPLES OF A REHABILITATED CULVERTS
AFTER COMPLETING STEPS 1-11**



NOSE CONE CONSTRUCTION

CREATING A NOSE CONE

Follow the below steps and figures to create a nose cone with 8 connection points on the end of a piece of pipe.

- Step ①** Determine X and L (minimum). $X = \pi d / 8$ and $L = d / 2$ where d = pipe outside diameter. For 16" and smaller pipes, L can be equal to the diameter. (Refer to Figure 4-1 and Figure 4-2 on next page)
- Step ②** Mark a line all the way around the pipe OD at L distance from end.
- Step ③** Mark top dead center (TDC) on pipe at end and at L distance from end.
- Step ④** Starting at TDC, mark every X distance around the pipe OD at the line made L distance from the end. (See figure 4-1)
- Step ⑤** Starting at X/2 from TDC, mark every X distance around the pipe at the end of the pipe.
- Step ⑥** Connect the marks from end of pipe and L distance to create the triangles to be cut out. (See figure 4-2)
- Step ⑦** Drill holes near the point at the pipe end. Holes will be dictated by wire rope size and flexibility. (See figure 4-2)
- Step ⑧** Cut out triangle shapes from end of pipe. (See figure 4-2 and 4-3)
- Step ⑨** Draw points together to create cone shape. (See figure 4-4)

FIGURE 4-1
PIPE OD UNROLLED FOR VISUAL

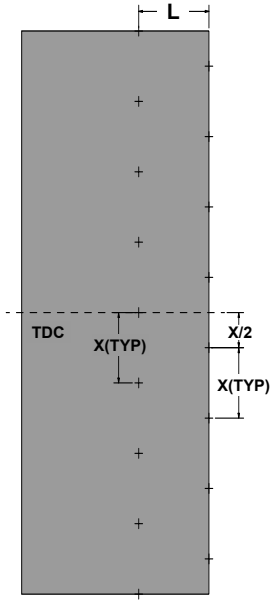

FIGURE 4-2

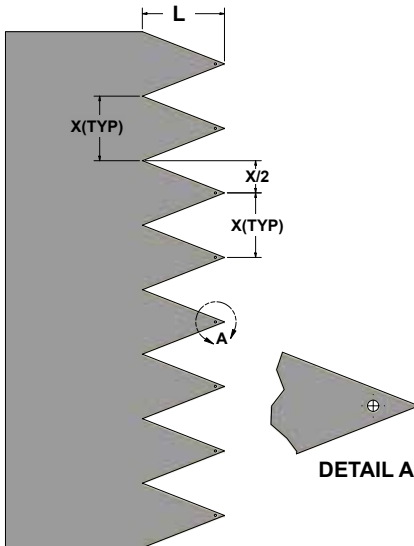

FIGURE 4-3
LINER AFTER CUTS

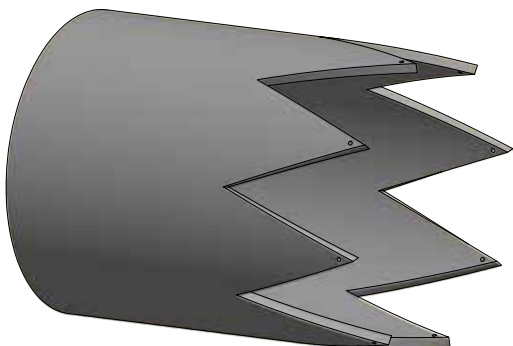

FIGURE 4-4
NOSE CONE DURING FORMING



OVAL PIPE RECOMMENDATIONS

INSTALLATION: BRACING AND JOINT COMPLETION

The creation of the oval Snap-Tite® is accomplished through controlled deformation and factory installed bracing to maintain the shape of the product until the liner pipe has been fully installed. Round Snap-Tite is put in a hydraulic press machine and deflected down, in a controlled manner, to the design dimensions. The ends of the polyethylene pipe are also affected by a stress relief reaction of “toe-in” or neck down. This stress relief reaction naturally occurs in plain HDPE pipe ends and is further exacerbated by removing material in the machining process to create the male and female profiles for connection. The combined stresses of deflection (ovalization) and machining, along with the viscoelastic nature of polyethylene pipe, can occasionally result in irregular shaped oval Snap-Tite ends, which may be a little out of balance or “fish-mouthed”.



**UNBALANCED AREA
OF JOINT, CREATED
DURING THE OVAL
PROCESS**

The oval pipe will be delivered with a horizontal strut grid throughout the entire length of the pipe. A vertical strut (I-beams) will be provided at the female end of the pipe, and may also be installed at the male end in some situations. The vertical struts are installed at the plant to prevent further “fish-mouthing” while the oval Snap-Tite awaits shipment to the project location. Removal of the vertical struts is not recommended until the joints are ready to be snapped together. The horizontal struts should NOT be removed until the entire liner is installed and grouted into place.



Removal of vertical struts at pipe ends should be done with great care. Rebound energy could be exerted by the pipe ends on the vertical strut to force it out during removal.

Insert the gasket into the first groove of the male end prior to pushing the joint together. Refer to Step 6 on page 35 for detailed instructions and illustrations. The use of sealing compounds like mastic or silicone may be allowed to assist in sealing at the joints. The use of sealing compounds may be necessary in situations like excessive deformations from storage or cold weather, where the pliable nature of the joint is challenged.

To complete the Snap-Tite oval joint, you may need additional tools to help the irregular ends line up. Contractors have successfully utilized crow bars to get the female joint worked around the male joint. Once the joint is started, the male joint should firm up the female joint. Since the polyethylene material is ductile and flexible, especially at warmer temperatures, sitting in the sun and/or the use of a heat blanket may also help the pipe become more “pliable” and allow the joint to complete easier.

NOTE: A ‘weed burner’ or any other flame device is NOT recommended to heat the pipe due to the risk of localized damage like melting or blistering, much like a candle. HDPE materials or sealing compounds may burn with prolonged exposure to open flame.



Removal of internal braces of the Snap-Tite® liner prior to insertion into the host pipe and completion of grouting is not recommended and should be avoided.

Without external restraint, removing some of the bracing material can release stored energy and a spring-like rebound of the pipe to a more circular shape (nearly round) condition is expected. Also, removal of internal bracing prior to grouting can damage grout tubes or any blocking/spacers that have been installed in the host pipe to prevent buoyant forces. Removal of bracing may also restrict the flow of grout that can pass between the HDPE liner and the host pipe. Cured grout around the encapsulated pipe will stabilize and manage the forces after removal of bracing.



**HOW A
VERTICAL
STRUT
SHOULD
LOOK AT A
PIPE END**

OVAL PIPE GROUTING

Chapter 7 of the Snap-Tite Design Manual has extensive information and recommendations, but key elements related to oval pipe are identified here.

The use of low-density cellular grouts are recommended and should be placed in the annulus between the host pipe and liner pipe prior to removing bracing. Grout pressures present on the oval liner product should be limited to 2 psi or less during grout placement. Excessive grout pressures placed on an oval pipe may increase the risk for pipe buckling, especially at the invert of the pipe where bracing may not be present.

Grouting in lifts is also considered a prudent approach to limit excessive grout pressures. Grouting of the HDPE liner pipe will reduce some of the compressive forces on the internal bracing, while also stabilizing the liner pipe, allowing for less resistance during removal.

OVAL PIPE HANDLING AND STORAGE

Pages 3-10 have extensive information and recommendations, but additional elements are identified here.

While oval pipe may have been stacked for shipping, it is recommended not to stack oval pipes on site, to prevent further deflection and loading on bracing. Oval pipes should be laid straight, not crossing over or entangled with each other. Movement, rolling, or shifting of oval pipe is less likely than round pipe, but blocking is still recommended.



Supports and cribbing from the shipment of the oval pipe is recommended to assist with site storage upon unloading.

FIBERGLASS HYDRO-BELL INSTALLATION

STANDARD INSTALLATION

The plain end of the Hydro-Bell is designed to fit into the Female End of Snap-Tite® pipe. The Hydro-Bell has the same ID as the Snap-Tite pipe, but the end of the Hydro-Bell has an OD that is smaller than the ID of the Female Snap-Tite end. When the Hydro-Bell is slid into the female end (similar to a male Snap-Tite would but without any ridges for interlocking) and it will butt up to the machined stop at the end of the female section. The Seal Tite rubber coupling will slide over the female HDPE pipe end and should rest on the raised portion of the fiberglass body. Each end of the rubber coupling is clamped using the worm drive clamps provided with the coupling. Additional installation details are available for different backfill and headwall arrangements are available from your local Snap-Tite representative.

FIGURE 6-1

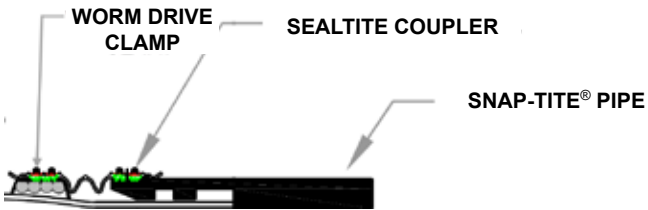
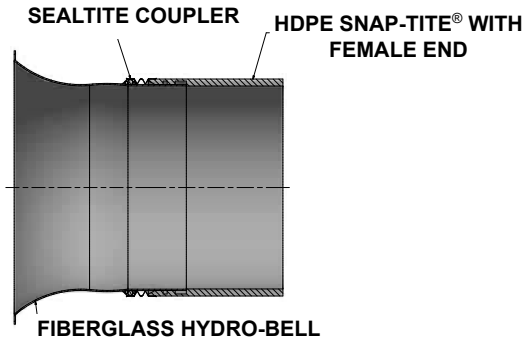

FIGURE 6-2



NON-STANDARD INSTALLATION

When it is not possible to connect to a Snap-Tite female end, it is possible to connect to a plain end of HDPE pipe. The plain end of the Hydro Bell will butt up against any plain cut HDPE pipe, but the wall thicknesses on the two products are different which will result in a mismatch between each OD. If a male end of HDPE is presented for connection, it should be cut back until the solid wall is presented with a square cut. A special adaptor collar can be provided to adapt to plain end pipes but advance planning should identify the need for this adapter for verification of pipe dimensions.

FIGURE 6-3

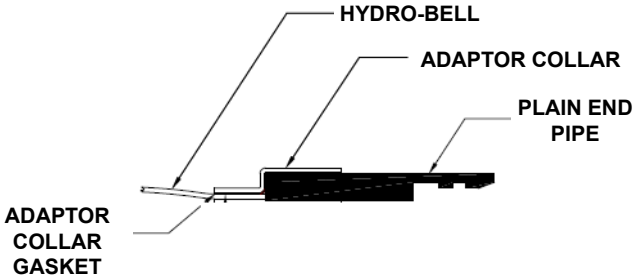

FIGURE 6-4



CUTTING AND SHAPING THE HYDRO-BELL FOR CUSTOMIZED INLET

The Hydro-Bell is provided with an extended flat face that can be used as an attachment point for existing headwalls, with equally spaced holes in the corners to assist in marking and drilling pilot holes. There are also reference lines for ease of cutting to final shape requirements. A circular indentation mark is made at the round to flat transition for removal of the flat face, if desired. Two horizontal lines are provided at the bottom to assist in making a square cut so that the bottom of the Hydro-Bell may rest at a lower point. The bottommost line helps to locate the round entry at the lowest point. Above that is a line that can be used to remove all material below the invert of the Hydro-Bell and piping system. Removal of material along the bottom of the Hydro-Bell is expected to have a negligible effect on flow as the Hydro-Bell is most efficient when water increases above to top of the round entry.

FIGURE 6-5

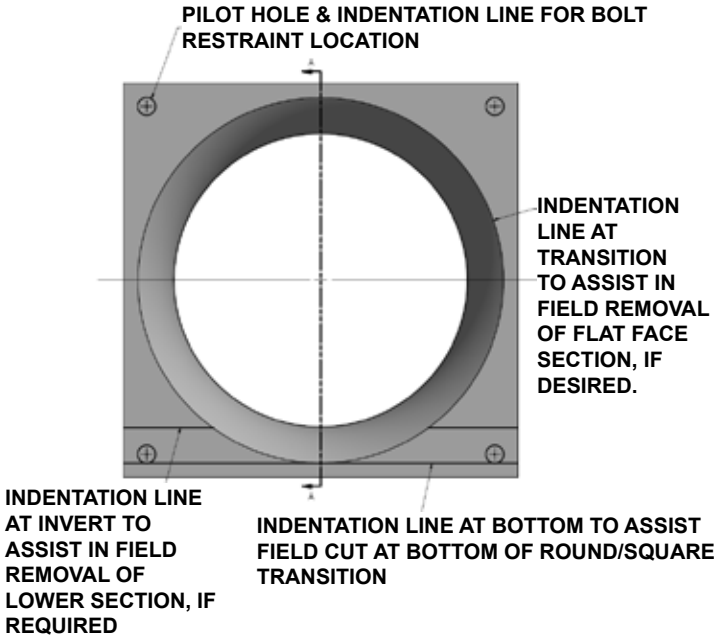

HYDRO-BELL GROUTING AND FINISHING

The extended flat face of the Hydro-Bell can also be used as one edge of a form to finish the entrance preparation with a concrete headwall. Plan accordingly to arrange for vent and grout tubes, as allowances may need to be considered. Ensure that grout can enter the annular space through the bulkhead. Be sure that the connection to the female end of the Snap-Tite is encased in the headwall, bulkhead, or grouted annulus.



Ideally, the Hydro-Bell is flush with an existing headwall or is part of the new headwall such that water is entering the pipe at the highest efficiency. When possible, place fill behind the Hydro-Bell so there is no space for water to get behind the top and sides of the Hydro-Bell face before entering the pipe. This may not always be possible to construct. Consult your local Snap-Tite representative or the website for more installation and connection detail examples.



HYDRO-BELL ENVIRONMENTAL RESISTANCE

The Hydro-Bell has carbon black added for UV resistance. No degradation is expected for long-term exposure to sunlight. Additionally, the fiberglass Hydro-Bell is flame resistant to grass and brush fires with a flame spread rating of less than 25 when tested in accordance to ASTM E 84. The body is made with a Hexion 755-8590 corrosion resistant vinyl ester resin or equal.



HYDRO-BELL HANDLING AND STORAGE

Pages 3-10 have extensive information and recommendations, but additional elements are identified here.

Do not stack anything on the Hydro-Bell at any time during transportation or site storage. Supports/dunnage may be used to maintain clearance for forklift forks or lifting slings. Take care to insure no direct impacts against other surfaces or dropping on the ground.

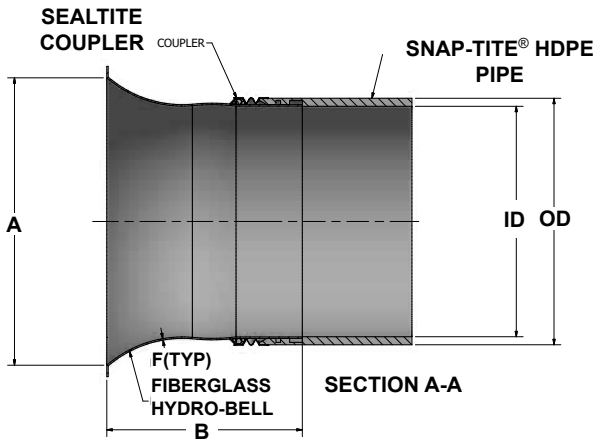
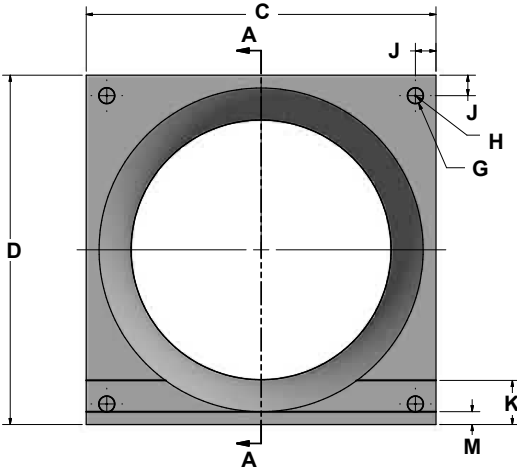

TABLE 6-1
SIZE AND DIMENSION REFERENCE CHART

FIBERGLASS HYDRO-BELL DIMENSIONS					
Pipe OD (In)	ID (in)	A (in)	B (in)	C (in)	D (in)
10.75	10.05	13.8	9	14.9	14.9
14	13.09	19.5	13.43	21.35	21.35
16	14.95	22.5	15.3	24.4	24.4
18	16.83	23.5	17.25	25.5	25.5
20	18.7	27.9	18.34	29.9	29.9
22	20.57	30	19.6	32	32
24	22.43	33.5	22	35.5	35.5
28	26.17	36.1	20.8	38.1	38.1
30	28.04	40.5	23.21	42.5	42.5
32	29.91	42	24.71	44.97	44.97
36	33.65	47.5	28	49.8	49.8
42	39.26	55	33.8	57.8	58.1
48	44.87	30	36	63.1	63.1
54	50.48	63	42.8	68	68
63	58.88	76	40.45	80	80



FIBERGLASS HYDRO-BELL DIMENSIONS

F (in)	G (in)	H (in)	J (in)	K (in)	M (in)	Pipe OD (In)
0.13	0.62	0.04	0.83	2.5	0.5	10.75
0.13	0.75	0.05	1.45	4.18	1	14
0.15	0.75	0.05	1.4	4.69	0.95	16
0.17	0.75	0.05	2	4.3	1	18
0.19	0.75	0.05	2	5.57	1	20
0.207	0.75	0.05	2	5.7	1	22
0.375	1.5	0.1	2	3.6	1	24
0.14	1.5	0.1	2	6.1	1	28
0.17	1.5	0.1	2	7.15	1	30
0.2	1.5	0.1	2	7.48	1.5	32
0.2	1.8	0.12	2	8	1.1	36
0.375	2.4	0.16	3.3	8.8	1.7	42
0.2	2.42	0.16	3	9	1.5	48
0.31	3.16	0.22	4	8.6	2.5	54
0.31	3.16	0.22	4	10.4	2	63



THE SNAP-TITE® SOLUTION

- Meets AASHTO Standard M326 for rehabilitating culverts.
- Flexibility to insert into misaligned concrete or rusted partially collapsed corrugated metal pipe.
- Tough, but thin, sidewall to give the highest flows possible after lining. The SnapTite joint makes a solid mechanical connection that can be pushed or pulled.

THREAD LINER INSTALLATION

STANDARD INSTALLATION

Thread-Liner pipe is provided with a male and female end on each section of pipe. One full revolution of the pipe will completely tighten one section of the pipe to the next. A matching chamfer on each mating piece will typically provide a tightened or locking engagement of the pieces.

Start with a counter-clockwise movement of the pipe till an audible thump is heard, typically no more than one quarter turn. Cross threading is a primary concern with getting started and the initial counter clockwise movement typically drops the male and female sections into the beginning engagement thread simultaneously. This action should help the alignment of the threads to a straight alignment position. Visually check for axial alignment of the two pipe sections at intervals around the circumference of the pipe.

THREAD SEALANT

Thread-Liner pipe is made by creating a male and female thread on the HDPE pipe. Those threads have a loose engagement to allow some rotation. It is not expected that the threads will create a liquid tight seal on their own. It is recommended to apply a thread sealant or a silicone caulk to the threaded sections, especially heavy at the ends where the chamfer engagement occurs. Thread sealants are not expected to create a pressure rated seal but will keep grout from bypassing the joints till setting up and keeping the effluent from escaping the pipe.

TOOLS

Wraparound nylon strap wrenches are the preferred tool to rotate the pipe in the threading process. Depending on the size of the Thread-Liner pipe, heavy equipment and straps to hold the pipe at the proper elevation may be needed.

Creativity may be the key to finding the right approach, especially as the size of the pipe increases. Attached are photos of a tool (a two prong bar wrench may be the best description)



that can be used to help provide torque at the end of the pipe assuming there is enough clearance. The two bars must have a separation larger than the wall thickness of the pipe and extend past the male or female sections of the pipe, and designed not to press or cut into machined end portions, so as not to damage the plastic threads.



THREAD-LINER ENVIRONMENTAL RESISTANCE

Thread-Liner pipe has carbon black added for UV resistance. No degradation is expected for long-term exposure to sunlight.

THREAD-LINER HANDLING AND STORAGE

Pages 3-10 have extensive information and recommendations, but additional elements are identified here.

Take special care to protect from any damage to the threaded ends of pipe. The storage site should be relatively smooth, flat, level surface free of stones, debris, or other material that could damage pipe or components, or interfere with handling. Supports/dunnage may be used to maintain clearance for forklift forks or lifting slings. Take care to insure no direct impacts occur against pipe and other surfaces, nor should the pipe be dropped on the ground.



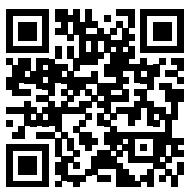

Scan here to view more
Snap-Tite literature.



CULVERT-REHAB.COM • 800-CULVERT