

Spirolite

**BULLETIN No. 914 – PIPE AND
FITTING INSTALLATION GUIDE**

ASTM F894/ ASTM D2321: Profile Wall High-Density Polyethylene Pipe and Fittings



 **PLASSON**[®]

USA

www.PlassonUSA.com

Plasson USA | 305 N 7th St., Corsicana, TX 75110 | 800-241-4175
Stafford, TX | Corsicana, TX



TABLE OF CONTENTS

General Requirements – Spirolite Pipe **pg. 3**

Design and Installation Considerations for Spirolite **pg. 4-6**

- Introduction
- Deflection Control
- Acceptance Deflection
- Pipe Design Considerations

Pipe Embedment Materials **pg. 6**

Terminology of Pipe Embedment
Materials Classification and Supporting
Strength of Pipe Embedment Materials
pg. 7-10

Use of Embedment Materials Compaction
of Embedment Materials **pg.11-14**

Trench Construction Trench Width
Stability of the Trench Bottom **pg.15-17**

Stability of Trench Walls **pg.17-18**

Water in the Trench **pg.19**

Trench Bottom Preparation **pg.19**

Base Preparation **pg.19-20**

Backfilling and Compaction **pg. 21-23**

Measuring Deflection **pg. 23-24**

Tunnel and Casing Construction **pg. 24-26**

Joining Spirolite Pipe-Rubber Gasket
System **pg. 27-28**

Orienting Pipe to Offset Service
Deflection
pg. 28

Important Reminders for Effective Seals
Procedure for Spirolite Gasket and
Joint Assembly **pg. 28-29**

This bulletin is intended to be used as a guide to support the designer in the use of Spirolite pipe. It is not intended to be used in the place of a professional design engineer. The information contained herein cannot be guaranteed because the conditions of use are beyond our control. The user of this bulletin assumes all risk associated with its use.

GENERAL REQUIREMENTS – SPIROLITE PIPE

Requirements for achieving satisfactory installation of Spirolite pipe are not more challenging than, nor uniquely different from, those for achieving the proper installation of traditional rigid piping products. This guide offers general recommendations which for the convenience of the user have been summarized in Tables 2a and 2b (see pages 9-10). The final requirements for any particular installation will be set by the engineers and should be followed.

Subsurface conditions should be adequately investigated and defined prior to establishing final project specifications. Subsurface investigations are necessary to determine types of soil that are likely to be encountered during construction, existence of rock, thickness of strata layers, and presence of ground water. These findings are useful both in specifying the proper pipe for an application and in planning construction procedures.

Prior to start of construction the on-site surface conditions, including water run-off, traffic, and other problems, should be appraised by a visual inspection of the proposed pipeline location. Also, all the construction documents, including plans, subsoil information, and product specifications, should be reviewed. All required permits should be obtained and arrangements made to insure compliance with all applicable federal, state, and local safety regulations.

The installation should be checked throughout the construction period by an inspector who is thoroughly familiar with the job site contract specifications, materials, and installation procedures. The inspection should reasonably ensure that significant factors such as trench depth, grade, pipe foundation, quality, and compaction of embedment and backfill, and safety comply with contract and other requirements.

This manual is to be used as a guide by the engineer, contractor, or installer in order to obtain a successful installation. It contains accurate and reliable information to the best of our knowledge. This information cannot be guaranteed, however, because the conditions of use are beyond our control. This document does not relieve the engineer, contractor, or installer of any responsibility for proper design of the installation.

It is recommended that the installer and his crew view the video Bury It! prior to installing Spirolite pipe. Copies of this video can be obtained from your Regional Sales Manager.



DESIGN & INSTALLATION CONSIDERATIONS FOR SPIROLITE INTRODUCTION

The load carrying capability of a buried Spirolite pipe evolves primarily from the soil in which the pipe is embedded. As the pipe is loaded, the load is transferred from the pipe to the soil by a horizontal outward movement of the pipe wall against the soil. This enhances contact between pipe and soil, and mobilizes the passive resistance of the soil. This works against further pipe deformation and contributes the primary support for the vertical loads. (See Figure 1.)

The interaction of the pipe with the soil contributes greatly to the efficiency and load carrying ability of the Spirolite pipe. This is in contrast to the behavior of a rigid pipe, which must use the inherent strength of the pipe itself as the primary source of support of earth loads. Properly installed, Spirolite pipe is capable of supporting earth fill loads of the same or greater magnitude than many rigid pipes. Moreover, the ability of Spirolite pipe to deform to significant levels without accompanying pipe or joint failure permits the pipe to redistribute stresses to the soil, thereby shedding off unanticipated loads that would fracture or otherwise fail many rigid pipes. The resultant deformation of a properly installed Spirolite pipe is usually relatively small when compared to the pipe's ultimate deformation limits.

Pipe deformation is controlled partly by selection of pipe wall stiffness but mostly by the nature of the pipe embedment-e.g. soil type, density, moisture content and the quality of its placement around the pipe. Use of suitable pipe embedment materials and their proper placement are essential to a good installation of Spirolite pipe.

Since large deformation in Spirolite pipe during installation usually signals a construction problem, checking pipe deformation soon after backfilling is often used to assess the quality of an installation. In contrast, poor installations of rigid pipes may not be discovered until years later when a pipe failure occurs.

FIGURE 1: MOBILIZATION OF ENVELOPING SOIL THROUGH PIPE DEFORMATION

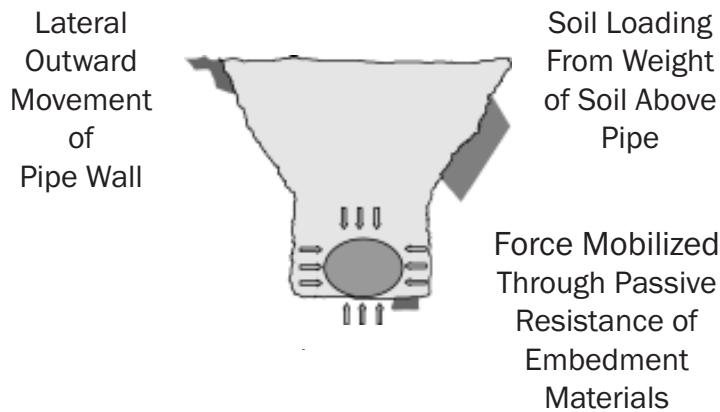

DEFLECTION CONTROL

The key objective of a Spirolite installation is to limit or control deflection. The extent of deflection of Spirolite pipe is usually assessed by measuring the reduction in the vertical diameter of the installed pipe. The resultant deflection of Spirolite pipe is the sum total of two major components: the installation deflection, which results from the technique and care by which the pipe is handled and installed; and the service deflection, which reflects the accommodation of the constructed pipe/soil system to the subsequent earth and other loadings.

Installation deflection may be positive (a decrease in vertical pipe diameter) or negative (an increase in vertical pipe diameter—a result of thrust in the pipe as the embedment material alongside the pipe is compacted). It is subject to control, however, by the care used in the placement and compaction of the pipe embedment material in relation to the pipe's ring stiffness. Because of this, Spirolite pipe has been categorized by Ring Stiffness Classes (i.e. by its parallel plate loading versus percent deflection characteristics see Bulletin No. 910 for detailed definition). Each Spirolite Ring Stiffness Class offers a uniform degree of resistance, independent of pipe diameter, to installation-related deflection. The major factor in pipe deformation is not the pipe's Ring Stiffness Class, however, but the quality of its installation.

Service deflection may be forecasted by a number of reasonably well documented relationships, including those of Watkins and Spangler. (See Bulletin No. 910 for further information.) Figure 2 of this guide presents, for typical installation parameters, estimates of the average value of the service deflection. These have been determined using the Spangler formula and soil constants established by extensive field observations conducted by the U.S. Bureau of Reclamation. Also shown in Figure 2 is the sum total of the calculated service deflection plus the estimated maximum installation deflection for a reasonably well installed Spirolite Class 40 pipe. The values in Figure 2 are primarily used for the designer's guidance.

FIGURE 2: INITIAL DEFLECTION USING IOWA EQUATION

Based on Data Reported By The U.S. Bureau of Reclamation

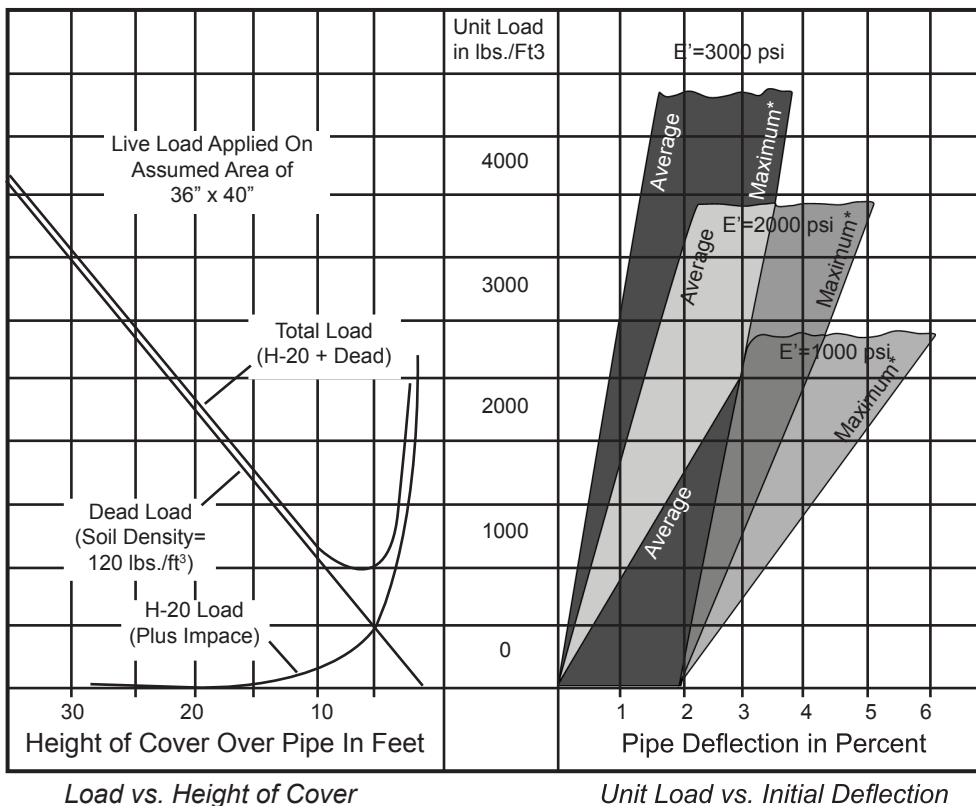

Deflection control is the key objective in the installation of flexible pipe. The pipe must be embedded with the proper materials and in such a manner that the deflection limits set by the designer will not be exceeded during and after construction.

*Maximum values are best estimates for Class 40 pipe.

ACCEPTANCE DEFLECTION

To evaluate and control the quality of a Spirolite installation, many designers impose an acceptance deflection requirement. The acceptance deflection is the vertical pipe deflection measured some short period following installation after allowing initial soil consolidation to occur. The acceptance deflection set by the designer is usually 7.5% or less. (See ASTM F-894 Appendix X2 for deflection limits.) Detailed methods for measuring deflection are presented in Measuring Deflection on page 23.

PIPE DESIGN CONSIDERATIONS

While control of pipe deflection is a key objective in the installation of Spirolite pipe, deflection is not ordinarily the criterion that determines the selection of a specific Spirolite pipe wall construction. For typical burial conditions, most wall constructions of Spirolite pipe, when properly installed, are adequately stiff to preclude excessive deflection. However, the selection of pipe wall construction may often be controlled by its buckling resistance and/or allowable compressive load. The engineer will select the pipe wall and establish final pipe construction requirements in consideration of anticipated site conditions including trench depth, rising and falling water table, hydrostatic pressure due to ground water, superimposed static or traffic loading, and minimum depth of cover. (See Bulletin No. 910 for more information.)

PIPE EMBEDMENT MATERIALS

The materials enveloping Spirolite pipe must provide adequate strength, stiffness, and stability to continually resist the pressures exerted at the sides and bottom of the pipe, thereby controlling pipe deformation. To ensure that this function will always be carried out under the anticipated job conditions, the engineer will specify the permissible pipe embedment material and their minimum acceptable density.

The properties of the native soil into which the pipe is installed need not be as demanding as those for the embedment materials immediately enveloping the pipe. However, the in situ soil containing the installed pipe and embedment materials must be adequate to permanently, and stably, contain this system. Any inadequacy of native soils should be taken into account when designing the installation. Soil stability requirement guidelines are presented in Trench Construction, page 15.



TERMINOLOGY OF PIPE EMBEDMENT MATERIALS

The materials enveloping a buried pipe are generally identified (as shown by Figure 3 on the following page) by their function or location.

Foundation: A foundation is only required when the native trench bottoms do not provide either a firm working platform or the necessary uniform and stable support for the installed pipe.

Bedding: In addition to bringing the trench bottom to required grade, the bedding levels out any irregularities and ensures uniform support along the length of the pipe.

Haunching: The backfill under the haunches of the pipe supports the pipe and distributes its superimposed loadings. The nature of the haunching material and the quality of its placement are the most important factors in limiting the deformation of Spirolite pipe.

Primary Initial Backfill: This zone of backfill provides the primary support against lateral pipe deformation. To ensure such support is available, this zone should extend from trench grade up to at least 75% of the pipe diameter. Under some conditions, such as when the pipe will be permanently below the ground water table, the primary initial backfill should extend over the pipe as described in Backfilling and Compaction, page 20.

Secondary Initial Backfill: The basic function of the material in this zone is to distribute overhead loads and to isolate the pipe from any adverse effects of the placement of the final backfill.

Final Backfill: Although the final backfill is not an embedment material, its nature and quality of compaction may be of direct consequence to a flexible pipe installation as increasing the density of the backfill promotes arching. To preclude the possibility of impact or concentrated loadings on the pipe both during and after backfilling, the final backfill should be free of large rocks, stumps, and debris. The material and compaction requirements for the final backfill should reflect sound construction practices and satisfy local ordinances and sidewalk, road building, or other applicable regulations.

FIGURE 3: PIPE TRENCH

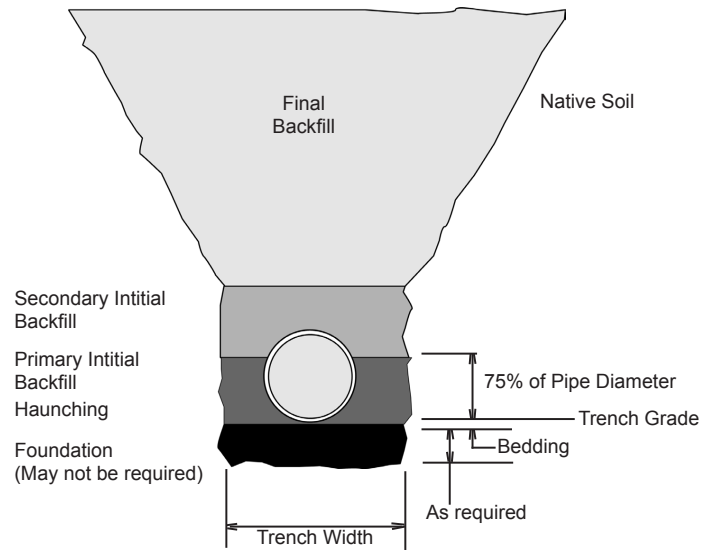

CLASSIFICATION AND SUPPORTING STRENGTH OF PIPE EMBEDMENT MATERIALS

Pipe embedment materials have been grouped by ASTM D-2321, Underground Installation of Flexible Thermoplastic Sewer Pipe, into five embedment classes. The materials included in each Class are identified in Table 2a on page 9. Class I covers manufactured materials, while Classes II through V cover naturally occurring soils that have been grouped in accordance with their classification per ASTM D-2487, Standard Unified Soil Classification System (USCS). A visual procedure for the field identification of soils is offered in ASTM D-2488.

The supporting strength of embedment materials roughly coincides with their embedment Class and, within each Class, this property is considerably dependent on the degree to which the material is compacted. Based on extensive evaluation of field and laboratory performance of flexible pipe, the Bureau of Reclamation, U.S. Department of the Interior, has issued Modulus of Soil Reaction Values (E'). These values are used in the Iowa (or Spangler) equation that is now in widespread use for predicting service induced pipe deflections. E' provides a measure of available soil support depending on the soil embedment Class and its degree of compaction. (A tabulation of values of E' suitable for Spirolite pipe can be found in Table 1 on page 7.)

As soils become finer-grained, they tend to offer less supporting strength. However, within any embedment Class, increased compaction greatly improves a soil's supporting strength-hence the critical role of proper compaction, particularly with finer-grained soils. To ensure that Spirolite pipe is always adequately supported, it is the general practice to use materials and degrees of compaction resulting in an E' equal to or greater than 1000 psi. (The application will dictate the minimum E' value.)

TABLE 1: VALUES OF E' FOR SPIROLITE PIPE, BASED ON BUREAU OF RECLAMATION VALUES OF E' FOR IOWA EQUATION

CLASS ASTM D-2321	SOIL TYPE FOR PIPE BEDDING MATERIAL (UNIFIED CLASSIFICATION SYSTEM*1)	DUMPED	SLIGHT <85% STD PROCTOR*3 <40% REL. DEN.*4	MODERATE 85-95% STD. PROCTOR 40-70% REL. DEN.	HIGH >95% STD. PROCTOR >70% REL. DEN.
I	Crushed Rock Manufactured angular, granular material with little or no fine. (1/4" - 1 1/2")	1,000	3,000	3,000	3,000
II	Coarse-Grained Soils with Little or No Fines GW, GP, SW, SP*2 containing less than 12% fines (maximum particle size 1 1/2")	Not Recommended	1,000	2,000	3,000
III	Coarse-Grained Soils with Fines GM, GC, SM, SC*2 containing more than 12% fines (maximum particle size 1 1/2")	Not Recommended	Not Recommended	1,000	2,000
IVA	Fine-Grained Soil (LL<50) Soils with medium to no plasticity CL, ML, ML-CL, with more than 25% coarse-grained particles	Not Recommended	Not Recommended	1,000*5	2,000*5
IVA	Fine-Grained Soils (LL>50) Soils with high plasticity CH, MH, CH-MH Fine-Grained Soils (LL<50) Soils with medium to no plasticity CL, ML, ML-CL, with less than 25% coarse-grained particles	Not Recommended	Not Recommended	Not Recommended	Not Recommended
	Accuracy in Terms of Percentage Deflection	±2	±2	±1	±.5

*1. ASTM Designation D 2487, USBR Designation E-3

*2. Or any borderline soil beginning with some of these symbols (i.e. GM, GC, GC-SC)

*3. Percent Proctor based on laboratory maximum dry density from test standards using about 12,500'-lb/ft³ (598,000 joules/m³) (ASTM D-698, AASHTO 99, USBR Designation E-11)

*4. Relative Density per ASTM D 2049.

*5. Under some circumstances Class IVA soils are suitable as primary initial backfill. They are not suitable under heavy dead loads, dynamic loads, or beneath the water table. Compact with moisture content at optimum or slightly dry of optimum. Consult a Geotechnical Engineer before using.

NOTES:

1. organic soils OL, OM, and PT, as well as soils containing frozen earth, debris, and large rocks are not recommended for initial backfill.
2. Not Recommended= Use not recommended per ASTM D-2321.

TABLE 2A: CLASSES OF EMBEDMENT AND BACKFILL MATERIALS, PER ASTM D 2321

CLASS	TYPE	SOIL SYMBOL GROUP	DESCRIPTION	PERCENTAGE PASSING SIEVE SIZES	ATTERBERG LIMITS	COEFFICIENTS
IA	Manufactured Aggregates that are open-graded and clean	None	Angular, crushed stone or rock, crushed gravel, broken coral, crushed slag, cinders, or shells; large void content, contains little or no fines.	1 1/2" (40 mm): 100 #4 (4.75m m): <10 #200 (0.075 mm): <5	ILL: Non-Plastic PI: Non-Plastic	
IB	Manufactured, Processed Aggregates that are dense- graded and clean	None	Class IA materials or stone/sand mixtures with gradations selected to minimize migration of adjacent soils; contains little or no fines.	1 1/2" (40 mm): 100 #4 (4.75mm): < 50 #200 (0.075 mm): <5	ILL: Non-Plastic PI: Non-Plastic	
II	Coarse-grained soils, clean	GW	Well-graded gravels & gravel-sand mixtures; little to no fines	1 1/2" (40 mm): 100 #4 (4.75mm): <50 of material retained on a #200 sieve	ILL: Non-Plastic PI: Non-Plastic	UNIFORMITY: (Cu)>4 CURVATURE (Cc): 1 to 3
		GP	Poorly-graded gravels and gravel-sand mixtures; little or no fines	#200 (0.075 mm): <5		UNIFORMITY (Cu): <4 CURVATURE (Cc): <1 or >3
		SW	Well-graded sands and gravelly sands; little or no fines	1 1/2" (40 mm): 100 #4 (4.75mm): >50 of material retained on a #200 sieve		UNIFORMITY (Cu): >6 CURVATURE (C _c): 1 to 3
		SP	Poorly-graded sand gravelly sands; little or no fines	#200 (0.075 mm): <5		UNIFORMITY (Cu): <6 CURVATURE (Cc): <1 or >3
	Coarse-Grained Soils, borderline clean to w/ fines	e.g. GW-GC, SP-SM	Sands, gravels, borderline between clean and w/ fines	1 1/2" (40 mm): 100 #4 (4.75mm): varies #200 (0.075 mm): 5-12		Same as for GW, GP, SW, and SP
III	Coarse-Grained Soils with fines	GM	Silty gravels, gravel-sand-silt mixtures	1 1/2" (40 mm): 100 #4 (4.75mm): <50 of material retained on a #200 sieve	LL: - PI: <4 or <"A" line	
		GC	Clayey gravels, gravel-sand-clay mixtures	#200 (0.075 mm): 12-50	LL: - PI: <7 & >"A" line	
		SM	Silty sands, sand-silt mixtures	1 1/2" (40 mm): 100 #4 (4.75mm): >50 of material retained on a retained on a #200 sieve	LL: - PI: >4 or <"A" line	
		SC	Clayey sands, sand-clay mixtures	#200 (0.075 mm): 12-50	LL: - PI: >7 & >"A" line	
IVA	Fine-Grained Soils (inorganic)	ML	Inorganic silts and very fine sands, rock flour, silty or clayey fine sands, silts with slight plasticity	1 1/2" (40 mm): 100 #4 (4.75m m): 100	LL: <50 PI: <4 or <"A" line	
		CL	Inorganic clays of low to medium plasticity, gravelly clays, sandy clays, silty clays, lean clays	#200 (0.075 mm): >50	LL: <50 PI: >7 and >"A" line	
IVB	Fine-Grained Soils (inorganic)	MH	Inorganic silts, micaceous or diatomaceous fine sandy or silty soils, elastic soils	1 1/2" (40 mm): 100 #4 (4.75mm): 100	LL: <50 PI: <"A" line	
		CH	Inorganic clays of high plasticity, fat clays	#200 (0.075 mm): >50	LL: >50 PI: >"A" line	
V	Organic Soils	OL	Organic silts and organic silty clays of clays of low plasticity	1 1/2" (40 mm): 100	LL: <50 PI: <4 or <"A" line	
		OH	Organic clays of medium to high plasticity, organic silts	#4 (4.75mm): 100 #200 (0.075 mm): >50	LL: >50 PI: >"A" line	
	Coarse-Grained Soils, borderline clean to w/ fines	e.g. GW-GC, SP-SM	Peat and other high organic soils			

TABLE 2B: RECOMMENDATIONS FOR INSTALLATION AND USE OF SOILS AND AGGREGATES FOR FOUNDATION, EMBEDMENT, AND BACKFILL, PER ASTM D 2321

	CLASS IA	CLASS IB	CLASS II	CLASS III	CLASS IVA	CLASS IVB
General Recommendations and Restrictions	Do not use where conditions may cause migration of fines from adjacent soil and loss of, pipe support. Suitable for use as a drainage blanket and underdrain in rock cuts where adjacent material is suitably graded.	Process materials as required to obtain gradation which will minimize migration of adjacent materials. Suitable for use as drainage blanket and underdrain.	Where hydraulic gradient exists check gradation to minimize migration. "Clean" groups suitable for use as drainage blanket and underdrain.	Do not use where water conditions in trench may cause instability.	Obtain geotechnical evaluation of proposed material. May not be suitable under high earth fills, surface applied wheel loads and under heavy vibratory compactors and tampers. Do not use where water conditions in trench may cause instability.	Not recommended
Foundation	Suitable. Also for replacing over-excavated and unstable trench bottom as restricted above. Install and compact in 6" maximum layers.	Suitable. Also for replacing over-excavated and unstable trench bottom. Install and compact in 6" maximum layers.	Suitable. Also for replacing over-excavated and unstable trench bottom as restricted above. Install and compact in 6" maximum layers.	Suitable. Also for replacing over-excavated and unstable trench bottom as restricted above. Do not use in thicknesses greater than 12" overall. Install and compact in 6" maximum layers.	Suitable only in undisturbed conditions and where trench is dry. Remove all loose material and provide firm, uniform trench bottom before bedding is placed.	Not recommended
Bedding	Suitable as restricted above. Install in 6" maximum layers. Level final grade by hand. Minimum depth 4" (6" in rock cuts).	Install and compact in 6" maximum layers. Level final grade by hand. Minimum depth 4" (6" in rock cuts).	Suitable as restricted above. Install and compact in 6" maximum layers. Level final grade by hand. Minimum depth (6" in rock cuts).	Suitable only in dry trench conditions. and compact in 6" maximum layers. Level final grade by hand. Minimum depth 4" (6" in rock cuts).	Suitable only in dry trench conditions and when optimum placement and compaction are maintained. Install and compact in 6" maximum layers. Level final grade by hand. Minimum depth 4" (6" in rock cuts).	Not recommended
Haunching	Suitable as restricted above. Install in 6" maximum layers. Work in around pipe by hand to provide support.	Install and compact 6" maximum layers. Work in around pipe hand to provide uniform support.	Suitable as restricted above. Install and compact in 6" maximum layers. Work in around pipe by hand to provide uniform support.	Suitable as restricted above. Install and compact in 6" maximum layers. Work in around pipe by hand to provide uniform support.	Suitable only in dry trench conditions and when optimum placement and compaction are maintained. Install and compact in 6" maximum layers. Work in around pipe by hand to provide uniform support.	Not recommended
Initial Backfill	Suitable as restricted above. Install to a minimum of 6" above pipe crown.	Install and compact to a minimum of 6" above pipe crown.	Suitable as restricted above, Install and compact to a minimum of 6" above pipe crown.	Suitable as restricted above. Install and compact to a minimum of 6" above pipe crown.	Suitable as restricted above. Install and compact to a minimum of 6" above pipe crown.	Not recommended
Embedment Compaction	Place and work by hand to insure all excavated voids and haunch areas are filled. For high densities use vibratory compactors.	Minimum density 85% Standard Proctor. Use hand tampers or impact vibratory compactors.	Minimum density 85% Standard Proctor. Use hand tampers or impact vibratory compactors.	Minimum density 90% Standard Proctor. Use hand tampers or impact vibratory compactors. Maintain moisture content near optimum to minimize compactive effort.	Minimum density 95% Standard Proctor. Use hand tampers or impact tampers. Maintain moisture content near optimum to minimize compactive effort.	Not recommended
Final Backfill	Compact as required by the Engineer.	Compact as required by the Engineer.	Compact as required by the Engineer	Compact as required by the Engineer	Suitable as restricted above. Compact as required by the Engineer	Not recommended

- NOTES:**
- Class IVB and V Materials are unsuitable as embedment. They may be used as final backfill as allowed by the Engineer.
 - Avoid contact with the pipe when using mechanical compactors. When compacting over pipe crown maintain a minimum of 6" cover when using small mechanical compactors. When using larger mechanical compactors maintain minimum clearances as required by the Engineer.
 - The minimum densities given in the table are intended as the compaction requirements for obtaining satisfactory embedment stiffness in most installation conditions.

USE OF EMBEDMENT MATERIALS

The determination of requirements for embedment materials and their placement should take into consideration not only their relative supporting strength but also their stability under end use conditions, ease of placement and compaction, and cost and availability.

Class I and II materials generally provide maximum and permanent support for a given density and compaction. In addition, Class I and II materials can be placed and compacted over a wide range of moisture content more easily than other materials. This tends to minimize pipe deflection during installation and in service. The high permeability of open-graded Class I and II materials aids in dewatering trenches, making these materials desirable in situations such as rock cuts where water problems may be encountered. This favorable combination of characteristics leads many designers to select these materials over others when they are readily and economically available.

Maximum aggregate size of Class I and II materials when used next to the pipe (i.e. bedding, haunching, and initial backfill) should not be larger than 1-1/2 inches. However, the maximum size should be selected to permit ease of placement under the pipe haunches. A maximum size of around 3/4" is generally quite suitable. Maximum size for the foundation is not restricted except that, if it is larger than 1-1/2", a suitable cushion should be provided between this material and the pipe.

When Spirolite is located beneath the ground water level, consideration must be given to the possibility of loss of side support through soil migration (the conveying by ground water of finer particle soils into void spaces of coarser soils). Generally, migration can occur only if all three of the following conditions exist:

- A significant gradient exists in the ground water from outside of the trench toward inside the trench, i.e. the trench must act as a drain. (Seasonal fluctuations of the ground water level normally do not create this condition.)
- The soil is erodible, i.e. dispersive clays, fine silts, etc. Under these condition clays have much higher resistance to erosion than silts.
- The void spaces in the embedment material must be sufficiently large to allow the intrusion of the eroded fines.

For such anticipated conditions, it is desirable when using granular materials (Class I and Class II) to specify that they be angular and graded to minimize migration.



Rounded particles have a tendency to flow when a considerable amount of water exists and material with high void content provides “room” for migrating particles. It is also desirable to use the same material and gradation for both the foundation and the embedment. The Corps of Engineers developed the following particle size requirements for properly grading adjacent materials to minimize migration:

- D15 of the embedment soil is less than 5 times D85 of the adjacent in situ soil.
- D50 of the embedment soil is less than 25 times D50 of the adjacent in situ soil.

(D15, D50, and D85 are the particle sizes from a particle size distribution plot at 15, 50, and 85%, respectively, finer by weight.)

Class III and IVA materials provide less supporting stiffness than Class I or II materials for a given density or compaction level. In addition, they require greater compactive effort to attain specified densities, and their moisture content must be closely controlled to within the optimum limit. Ease of placing and compactability of Class IVA materials are especially sensitive to moisture content, thus, these materials must be used with special care. ***Because of this difficulty, when Class IVA materials are used for embedment, a Geotechnical Engineer should be consulted.***

Class IVB and V materials offer hardly any support for a buried pipe and are often difficult to properly place and compact. ***Class IVB and V materials are not recommended for the embedment of Spirolite pipe.***

Cement Stabilized Sand is generally considered to give the same long-term supporting strength as compacted Class I material. Initial deflection of pipe in cement sand may be higher, as the embedment behaves like compacted sand until the cement cures. Cement stabilized sand typically contains 3-5% cement. The material must be placed moist but not saturated and then compacted in lifts like a Class II material. Where possible, deflection can be reduced if the cement sand embedment material is allowed to cure overnight before placement of backfill to grade—although this is not a requirement. Cement sand is usually placed in both the primary and secondary backfill zones (see Figure 3, page 7.)

COMPACTION OF EMBEDMENT MATERIALS

Because of the importance of the development of appropriate and uniform pipe support, compaction criteria for embedment materials are a normal requirement in flexible pipe construction. Compaction minimizes air voids and increases embedment density, greatly improving its load carrying ability while reducing deflection, settlement, and water infiltration problems. Factors that influence ease of soil compaction include:

- the nature of the soil, its gradation, and physical properties.
- moisture content of the soil (the “right” moisture content lubricates the soil particles, decreasing required compaction energy and permitting loss of air voids)
- depth of layer to be compacted
- type and amount of compactive effort
- the desired density (higher densities usually require more compactive effort)
- method of compaction

The required degree of compaction for an installation will be set by the designer in consideration of height of cover, extent of live loading, water table elevation, and soil properties. (See Bulletin No. 910.) Generally, the moderate compaction requirements listed in Table 1 (page 8) are quite satisfactory. When compacting to this moderate level, it is suggested that the minimum target values for field measured densities be set as 90% Standard Proctor Density, in accordance with ASTM D-698 A field density requirement of 90% will ensure that the actual densities will always be within the moderate range presented in Table 1 on page 8.

Compaction of the haunching material can best be accomplished by hand with tampers (see Figure 4) or suitable power compactors, taking particular care in the latter case not to disturb the pipe from its line and grade alignment. Care must be taken to properly compact material in the pipe haunches. In 42" and larger pipe this is often achieved by using suitable hand tampers to reach under the haunches, then follow up with power compaction alongside the pipe. If Class I material is used without compaction, care must be taken to hand place material in the haunches; the material should be cut into the haunches with shovels.

FIGURE 4: TAMPING TOOL

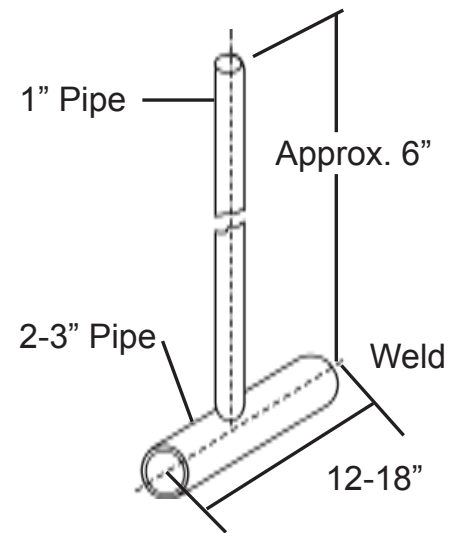

Compaction of other embedment material should be performed by the most economical method available, consistent with providing uniform compaction and attaining the minimum specified density. Compaction using pneumatic or mechanical tampers of the impact or vibratory type is usually most effective and practical. Where impact type tampers are used, caution should be taken not to allow direct contact of the equipment with the pipe. It also should not be used directly above the pipe until sufficient backfill has been placed to ensure that the use of the impact type compactor will not deform the pipe. Our experience has shown that compaction of the embedment material alongside the pipe will not cause the pipe to lift off the grade.

Compaction of the primary initial backfill should be conducted at or near the materials optimum moisture content. (See page 6 for definition of primary initial backfill.) The compaction should be accomplished in layers (or lifts) that are brought up evenly on both sides of the pipe. Each lift should be thoroughly compacted prior to placement of the next layer. The maximum lift height

that will allow development of uniform density will vary depending on the material, its moisture content, and the compactive effort. In general, maximum lifts are approximately 12” for Class 1, 8” for Class II, and 6” for Class III materials.

Compaction by vibration is most effective with granular (Class I and II) materials. Class I materials that are thoroughly “worked in” by shovel slicing (so no voids are present) will generally attain an E’ of 1000 without mechanical compaction. However, a few passes with a vibratory compactor is a good idea and will help in the removal of large voids which if present can permit increased local pipe deformation. This small, added effort also increases embedment material density and improves its supporting strength. In cases where the engineer specifies a relatively high minimum soil density (as for installations requiring an E’ higher than 1000) mechanical compaction of Class I materials will be required.

Mechanical compaction of Class II materials can be aided by wetting. Care must be taken not to flood the trench, particularly when the native trench material does not drain freely. Flooding can result in flotation of the pipe.

Compaction by saturation, also referred to as flooding or water tamping, may sometimes be used to compact Class II materials. *It is advised that where compaction by saturation is used, a Geotechnical Engineer specify the compaction method and determine the E’ achieved.* Compaction by saturation is limited to installations in which both the embedment and in situ materials are free draining—a prerequisite for the ready compaction of the embedment materials. When compacting by saturation, a lift of approximately 24” but not greater than the pipe radius should be evenly placed dry on each side of the pipe and then saturated, taking care not to float the pipe. Only enough water to saturate the materials should be used. The material is densified as the water drains off. The next lift is then placed and the saturation step repeated. Before any additional backfill is placed on top of a layer than has been saturated, that layer should first be sufficiently dried to support the weight of a man. Also, it should be determined through proper monitoring that the degree of compaction in the layer satisfies construction requirements. Compaction by saturation should not be used during freezing weather.

Water jetting, or the introduction of water under pressure to the embedment material, is not to be used with Spirolite pipe.

Compaction by impact is usually most effective with Class III and Class IVA materials. The use of mechanical or pneumatic impact tampers is most practical and effective. Depending on the embedment material, its moisture content, and lift height, several compaction passes may be required. A maximum lift height of 6” should be used when compacting by impact. Embedment density should be suitably monitored to ensure that specification requirements are met.

Monitoring compaction. It is prudent to routinely check density of the embedment material. Typically, several checks are made during the start-up of a job to ensure that the compaction procedure is achieving the desired density. Random checks are subsequently made to verify that the materials or procedures have not changed. Checks should be made at different elevations of the embedment material to assure that the desired compaction is being achieved throughout the embedment zone.

TRENCH CONSTRUCTION

Trenches should be excavated to line and grade as indicated by the plans or specifications and in accordance with applicable safety standards. Excavation should proceed upgrade. Excessive runs of open trench should be avoided to minimize such problems as trench flooding, caving of trench walls, and the freezing of the trench bottom and backfill material, and to minimize hazards to workmen and traffic. This can be accomplished by closely coordinating excavation with pipe installation and backfilling.

Principal considerations in trench construction are trench width, stability of the native soil supporting and containing the pipe and its embedment soil, stability of trench walls, and water accumulated in the trench. When encountering unstable soils or wet conditions, they should be controlled by providing an alternate foundation, sloping or bracing the trench walls, dewatering the trench bottom, or other appropriate measures.

TRENCH WIDTH

Since flexible pipe supports, at most, only the weight of the prism (or vertical column) of soil directly over the pipe, the precaution of keeping the trench as narrow as possible is not the concern that it is for a rigid pipe, which can be subjected to the weight of soil beside the prism as well as the prism itself. (See Figure 5.)

With Spirolite pipe, widening the trench does not significantly affect pipe loading. Trench width in stable soils is determined by the practical consideration of allowing sufficient room for the proper preparation of the trench bottom and placement and compaction of the pipe embedment materials, and the economic consideration of the costs of excavation and of imported embedment materials.

Trench width in stable soils will generally be determined by the compacting equipment used. The clearance between the trench sidewalls and the pipe spring line should be at least a couple of inches wider than the compacting plate. Typically, this requires clearance will vary 12" to 18". Somewhat narrower trenches can be used with pipes that are embedded in materials that can be adequately compacted by hand placement and tamping. However, in such cases the trench width should leave at least 9" on either side of the pipe to ensure proper placement and compaction of embedment materials. If two or more pipes are laid in the same trench, sufficient space must be provided between them so that embedment material can be compacted. Normally the distance is 12" to 18".

FIGURE 5: PRISM LOAD

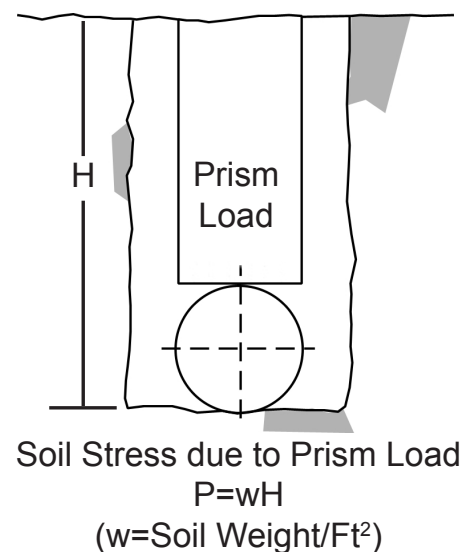

STABILITY OF THE TRENCH BOTTOM

Although the native soil in which Spirolite pipe is installed need not be as strong and stiff as the pipe embedment materials, it should provide adequate support and stable containment of the embedment material so that the density of the embedment material does not diminish. If the soil does not present construction problems such as walls that readily slough or a soft trench bottom that provides an inadequate working platform, it is termed stable. Those that are not are called unstable. The latter includes materials with high organic content (such as peats), fine grain soils saturated with water in excess of their liquid limit, low density fine sands or silts, and expansive soils such as “fat” clays and certain shales that exhibit a large change in volume with change in moisture content.

Soils stability requirements will be set by the engineer in consideration of specific job conditions. The following guidelines have been found useful in generally determining adequacy of in situ soil stability:

- For cohesive or granular cohesive soils, the shear strength as measured in accordance with ASTM D-2166 Test For Unconfined Compressive Strength of Cohesive Soils or D-2573 Field Vane Test in Cohesive Soils should be not less than 500 pounds per square foot.
- For sands, the penetration resistance as determined in accordance with ASTM D-1586 Penetration Test and Split Barrel Sampling of Soils should be not less than 8 blows per foot.

Stabilization of trench bottom may be accomplished by various cost effective methods which can be suited to overcome all but the most difficult soil conditions. Included among these are the use of alternate trench foundations such as wood pile or sheathing capped by a concrete mat, or wood sheathing with keyed-in plank foundation; the stabilization of the soil by the use of special grout, chemicals, or geofabric migration barriers; or by ballasting. A cushion of bedding material must be provided between any special foundation and the pipe. Permanently buried timber should be suitably treated.



Stabilization by ballasting is the removal of a sufficient quantity of undesirable material. This technique is frequently employed to stabilize randomly encountered short sections of unstable soil. The extent of required over-excavation and details of accompanying construction requirements will be determined by the engineer in consideration of the qualities of the unstable soil and the specific design requirements. The following are general guidelines. They are suitable for most situations excepting for extremely weak soils (such as quick sands, organic silts, and peats) which may call for further over-excavation or other special treatment.

- The trench bottom should be over-excavated throughout the full trench width from 24" to 36" below the pipe grade and then brought back to grade with a foundation of Class I material. An appropriate bedding should then be placed on the foundation. The grading of the foundation material should be selected so that it acts as an impervious mat into which neither the bedding nor other embedment material nor the surrounding native soil will migrate. (See the discussion on page 11 on migration control.) Trench width at the pipe springline should be increased to at least three pipe diameters. The pipe may be embedded in the materials specified for trenches in stable soils, but, as with the foundation material, their selection must consider the need for migration control. Embedment material should be compacted over the full width of the trench.

Monitoring the deflection of pipe installed in over-excavated trenches in unstable soil conditions can provide useful guidance in evaluating the adequacy of the procedure. If deflections tend to be larger than in stable soil construction, then wide trenches should be used.

STABILITY OF THE TRENCH WALLS

Walls of trenches below the elevation of the crown of the pipe should be maintained as vertical as possible. The shape of the trench above the pipe will be determined by the nature of the soil, excavation depth, surface loadings near the trench, proximity of existing underground structures, presence of ground or runoff water, and safety and practical considerations. These will determine if the trench walls may be vertical, excavated with sloped or benched sides, or shored. When trench walls are shored or otherwise stabilized, the construction scheme must allow for the proper placement and compaction of pipe embedment materials. Some suggested trench construction schemes follow. The final procedure must be in compliance with all applicable safety regulations.

Sloping of trench walls in granular and cohesionless soils should be provided whenever the walls are more than about four feet in depth, or otherwise required by state, local, or OSHA regulations. If the walls may not be sloped, they should be stabilized for safety by alternate means such as shoring or bracing. The slope should be no greater than the angle of repose of the materials being excavated and should be approved by the engineer.

Shoring or bracing will frequently be required in wet, fine grained, cohesive type soils and clays. Bracing of sheathing that is constructed of timber, steel, or other acceptable material may be used to stabilize trench walls. The design and placement of bracing or sheathing should meet all acceptable state, local, or OSHA regulations. Wherever possible, sheathing and bracing should be installed so that its bottom extends no lower than about 1/4 pipe diameter below the crown of the pipe, unless safety considerations or regulations dictate otherwise. When so installed, pulling the sheathing will minimally disturb the embedment material and the sidewall support it provides. Sheathing that is installed to project

CAUTION:
Removal of sheathing by vibratory extraction could cause excessive pipe deflection. Do not use a vibratory extractor.

below the pipe springline should be left in place unless, as with some thinner steel sheathing, it is designed to be pulled and removed without disturbing the embedment materials that support the pipe. If the sheathing is not of this type but has to be pulled, then (to minimize disturbing the embedment next to the pipe) it should be installed so that it is no closer than one pipe diameter from either side of the pipe and the void left by removal of the sheathing should be filled with embedment material. In addition, only granular materials (Class I and Class II), compacted to 90% proctor Density, should be used between the sheathing and the pipe. For situations where it is not possible to widen the trench (such as excavations along some city streets), consult PLASSON USA for suggestions. If timber sheathing is left in place, it should be suitably treated and cut off above the top of the pipe prior to final backfilling.



Portable trench shields (trench boxes) provide a moveable, safe area for workers installing pipe. New OSHA regulations require that the bottom of the shield be kept at the bottom of the trench. This requirement can and should be met when installing flexible pipe. The minimum inside clear width of the shield should allow the minimum trench width requirements to be met. When a trench shield is used with a flexible pipe, the installer will benefit by using a different technique than what he may have used with rigid pipe.

When rigid pipe is laid, it is important to provide a firm bedding beneath the pipe, whereas the soil alongside of the pipe may be less firm. This permits the installer who is using a trench shield to excavate the trench slightly wider than the shield, then move the shield into position such that the bottom of the shield is even with or slightly below the pipe grade. After the bedding and pipe are placed, sidefill soil can be dumped alongside the pipe. The backhoe operator then proceeds to dig out a new hole and to slide the shield without lifting from pipe grade into the next position. As the shield is moved, loose in situ soil sloughs into the void left by the shield between the sidefill soil and the in situ soil. This has little effect on the performance of a rigid pipe.

The installation procedure for rigid pipe creates a condition of loose sidefill soil. This loose soil will normally not provide sufficient support for a flexible pipe. More than likely, if the above procedure is used on flexible pipe, large deflections will occur and the pipe will require reinstallation. The construction procedure must be changed to accommodate flexible pipe. The changes that must be made include:

- Excavation of the trench below pipe crown elevation must be done from inside of the shield. That is, the backhoe must dig inside of the shield and force the shield down as soil is removed. Thus, once the shield has been positioned at pipe grade elevation, the outside of the shield is in contact with undisturbed in situ soil. After placement of the bedding within the shield and removal of the shield as described below, the embedment material will be placed against undisturbed in situ soil.
- After preparing the trench bedding and placing the pipe in the trench, the embedment must be placed alongside the pipe in lifts. After each lift is placed, the shield must be lifted so that embedment materials can be shoveled under the shield's sides to fill the voids created when moving the shield. It may be necessary to lift each end of the shield separately and in such a fashion that the shield is "rocked" upward.
- Once the bottom of the shield is lifted above the pipe crown elevation and clear of the embedment zone, it can be advanced to the position of the next pipe.

WATER IN THE TRENCH

Where water is present in the trench or where the trench bottom displays a “quick” tendency, the excess water should be removed by pumping from sumps, by using deep wells, a well point system, or an underdrain under the bedding. The removal of water should be continued while the pipe is being laid, the embedment placed and compacted, and until sufficient backfill is placed on the pipe to prevent its flotation upon the cessation of dewatering. Should the pipe become completely submerged under the ground water table, minimum cover as specified by the engineer should be provided to anchor the pipe against flotation.

When an underdrain layer is used, it should be of the appropriate material gradation, or surrounded with barrier material to prevent migration. (See discussion on page 11 on the use of embedment materials under wet conditions.) Perforated plastic pipe may be included in the underdrain layer to improve draining.

TRENCH BOTTOM PREPARATION

The trench base must provide firm, stable, and uniform support for the pipe. It must have sufficient stability and load bearing capacity to present a firm working platform during construction and to maintain the pipe at its required alignment and grade and sustain the weight of the fill materials placed around and over the pipe. The trench bottom should be smooth and free from sloughed side wall material, large stones, large dirt clods, frozen material, hard or soft spots due to rocks or low bearing strength soils, and any other condition that could lead to non-uniform or unstable support of the pipe. Any undesirable condition that is encountered must be corrected. The trench bottom must be kept dry during installation of the pipe and the embedment materials. All foundation and bedding materials must be approved by the engineer and placed and compacted in accordance with approved requirements. Such materials should also be selected to provide the necessary migration control when required.



BASE PREPARATION

Hard or sharp objects in the trench bottom such as boulders, large stones, ledge rock, hard pan and cobbles should be removed so that they are no closer than 6” from the pipe. Material that has sloughed off the trench side walls and fallen into the trench bottom should be removed.

Over-excavation of the trench bottom by more than 6” below grade requires that the over-excavation be filled with acceptable embedment material that is compacted to a density equal to that of the embedment material. If the over-excavation exceeds 12”, it should be brought to proper grade with a suitably graded Class I or Class II material that is compacted to the same density as that of the native soil but not less than the density requirements established by the engineer for the embedment materials.

In stable soils, the trench bottom should be undercut by machine and then brought up to proper grade by use of a well-leveled bedding consisting of a 4" to 6" layer of embedment material. This material should be compacted by mechanical means to at least 90% Standard Proctor Density or as specified by the engineer. If a Class I material is used, placement without compaction may be acceptable if it attains the density required for the installation by the engineer.

In unstable soils that may be too soft, low load bearing, or otherwise inadequate, the trench bottom must first be stabilized by soil modification, by providing an alternate foundation, or by the removal of the undesirable material and replacement with stable foundation material. The engineer will determine the appropriate method of stabilization for the encountered conditions. (See soil stabilization in the section on Trench Construction, page 15.) A cushion of at least 4" of compacted bedding should be provided between any special foundation and the pipe. Trench bottom stability is difficult to evaluate by visual observation and is, therefore, best determined by soil tests. However, a warning of a potentially unstable soil condition is given by a trench bottom that cannot support the weight of workmen without leaving their footprints in the soil.

Uneven support conditions where the grade line traverses both soft and hard spots requires special consideration. Ballasting is the most frequently employed technique chosen by the engineer to deal with randomly encountered short sections of soft soils. (See soil stabilization in the section on Trench Construction, page 15.)

Where differential conditions of pipe support might occur, such as in transitions from manholes to trench or from harder to softer soils, a transition support region should be provided to ensure uniform pipe support and preclude the development of shear or other concentrated loading on the pipe. The engineer will determine the procedure, which typically consists of the following:



- The soil next to the more rigid support is over-excavated to a depth of not less than 12" over a distance of 3 pipe diameters along the pipeline. Over the next 3 diameters away from the rigid support, the depth of over-excavation is gradually decreased until it meets the normal trench depth (see Figures 6 and 7). Pipe grade is then restored by the addition of granular material (Class I or II) that is highly compacted. In the case of connections to manholes and buildings, the distance of over-excavation along the pipe length should be no less than required to reach undisturbed soil.

Backfilling should follow pipe placement and assembly as closely as possible. Such practice prevents the pipe from being shifted out of line by cave-ins, protects the pipe from external damage, eliminates pipe lifting due to flooding of open trench, and, in very cold weather, lessens the possibility of backfill material becoming frozen. The quality of the backfill materials and their placement and compaction will largely determine the pipe's ultimate deformation and alignment. Backfill material should be selected with consideration of potential material migration to or from the trench wall and other layers of embedment materials. Placement and compaction of backfill materials should be in accordance with the engineer's requirements, per the guidelines shown in Figures 8 and 9 on page 22 (depending on the groundwater circumstances) and in the section on Embedment Materials, page 6. Under most circumstances, compaction will be required for all embedment material placed in the trench. The required density of the bedding, haunching, and the primary and secondary initial backfill material will depend on several considerations such as depth of cover, weight of soil, and surcharge loads. (See page 6 for definitions of primary and secondary backfill.) Unless otherwise specified by the engineer, the minimum density for these materials should be equal to 90% Standard Proctor Density. For Class II, III, and IVA materials, compaction by mechanical means will always be required to obtain these densities. Class I material placed without compaction will usually produce a modulus of soil reaction of 1000 psi when shovel sliced. This may be adequate for many installations.

Bedding performs a most important function in that it levels out any irregularities in the trench bottom, assuring uniform support and load distribution along the barrel of each pipe section and supports the haunching material. A mat of at least 6" of compacted embedment material will provide satisfactory bedding.

Haunching material must be carefully placed and compacted so as not to disturb the pipe from its line and grade while assuring that it is in firm and intimate contact with the entire bottoms surface of the pipe. Special tools (such as shown in Figure 4 on page 13) will assist in getting good compaction under the haunches. (See discussion on compaction of embedment materials, page 12.)

FIGURE 6: PIPE SUPPORT IN TRANSITIONS FROM RIGID SUPPORT TO NORMAL TRENCH SUPPORT

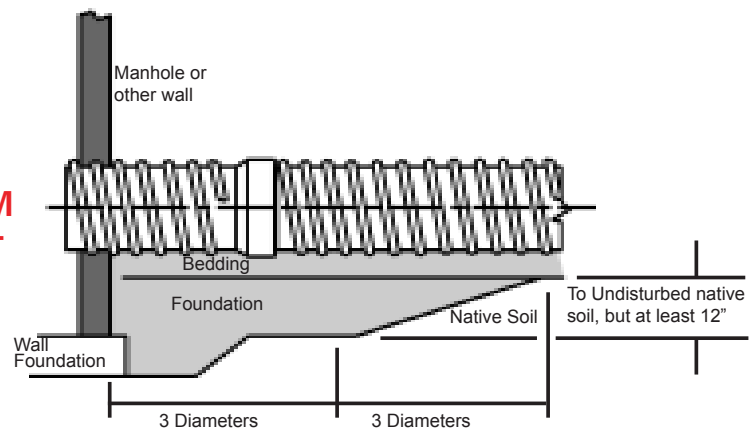
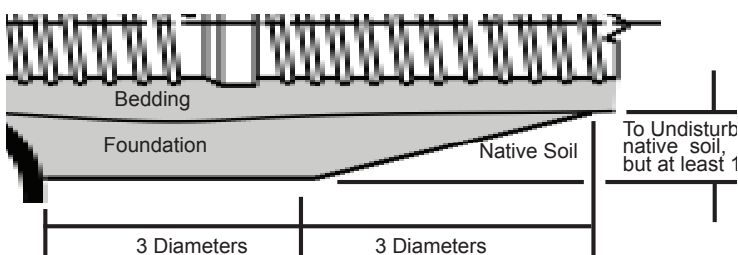
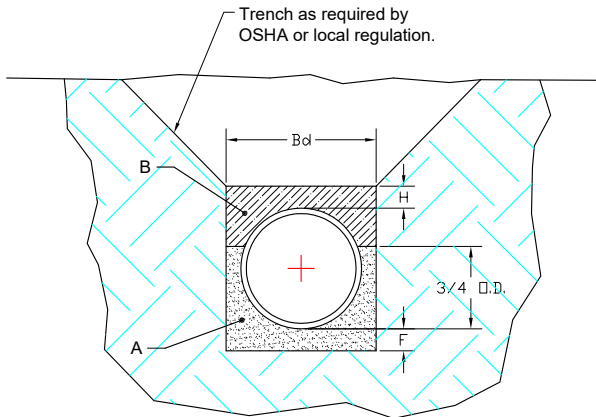

FIGURE 7: PROPER TRANSITION FROM SOIL TO ROCK TRENCH BOTTOM

FIGURE 8: EMBEDMENT RECOMMENDATIONS FOR SPIROLITE WHERE GROUNDWATER IS ALWAYS BELOW PIPE SPRINGLINE



Embedment recommendations for Spirolite where groundwater is always below pipe springline.

A	1/4"-1" Class 1, 11, or III Material If cover < 16', shovel Class I, compacted Class II or III (90% Std. Proctor) If cover > 16', Compact to 90% Std. Proctor (ASTM D-698) Class I or II only. If cover > 24, Use wet bedding installation
B	Selected Earth backfill compacted to 90% Std. Proctor
H	6" (18"-27" Ø Pipe) 12" (30-84" Ø Pipe) 18" (96-120" Ø Pipe)
F	4" (18"-30" Ø Pipe) 6" (33-84" Ø Pipe) 8" (96-120" Ø Pipe)
Bd	O.D. + 18" (18"-33" Ø Pipe) O.D. + 24" (36"-60" Ø Pipe) O.D. + 36" (66"-84" Ø Pipe) O.D. + 48" (96-120" Ø Pipe)

Selection of bedding material to be made by owner/owner's engineer on basis of pipe design requirements.

Primary initial backfill should be placed and compacted in lifts evenly placed on each side of the pipe. The lifts should not be greater than the limits specified by the engineer, which is usually 12" for Class I, 8" for Class II, and 6" for Class III and IVA materials. The primary initial backfill should extend up to at least 3/4 of the pipe diameter to perform its function of pipe side support as shown in Figure 3. If the construction does not call for the use of a secondary initial backfill, then the primary layer should extend to not less than 6" above the pipe crown. In any location where the pipe may be covered by existing or future ground water, the primary initial

backfill should extend up to at least 6" over the pipe crown for 18" through 27" pipe, to at least 12" over the pipe crown for 30" through 84" pipe, and at least 18" for 96" through 120" pipe.

Placement of Class I material as primary backfill without compaction will normally provide modulus of soil reaction of 1000 psi if shovel sliced. Care should be taken to shovel slice material under haunches. Just dumping stone into the trench will not provide adequate support. **Shovel slicing is essential for obtaining adequate side support.**

If primary initial backfill is to be compacted by saturation (see section on embedment materials, page 6), the approved embedment material must first be hand placed in layers of about 4" to a height sufficient to prevent flotation of the pipe, making certain that all voids under, around, and along both sides of the pipe are filled.

FIGURE 8: EMBEDMENT RECOMMENDATIONS FOR SPIROLITE WHERE GROUNDWATER IS ALWAYS BELOW PIPE SPRINGLINE

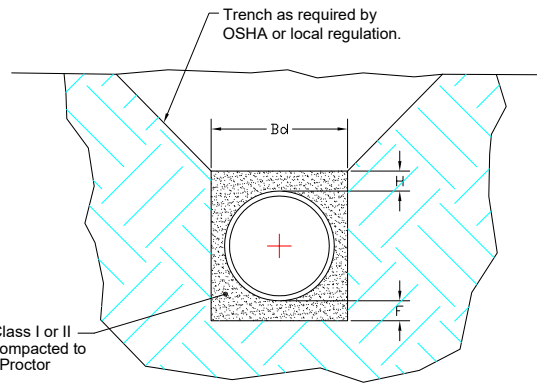

1/4" - 1" Class I or II material compacted to 90% Std. Proctor

Embedment recommendations for Spirolite where groundwater is sometimes or always above pipe springline.

H	= 6" (18"-27" Ø Pipe) = 12" (30-84" Ø Pipe) = 18" (96-120" Ø Pipe)
F	= 4" (18"-30" Ø Pipe) = 6" (33-84" Ø Pipe) = 8" (96-120" Ø Pipe)
Bd	= O.D. + 18" (18"-33" Ø Pipe) = O.D. + 24" (36"-60" Ø Pipe) = O.D. + 36" (66"-84" Ø Pipe) = O.D. + 48" (96"-120" Ø Pipe)

Selection of bedding material to be made by owner/owner's engineer on basis of pipe design requirements.

Secondary initial backfill serves to protect the pipe during the final backfilling operation and to provide support for the top portion of the pipe. It should extend up to at least 6" over the pipe crown for 18" through 27" pipe, to at least 12" over the pipe crown for 30" through 84" pipe, and at least 18" for 96" through 120" pipe. These depths can be modified slightly depending on the depth of burial, ground water level, and type of native soil.

Compaction of this layer should be to the same extent as that specified for the primary initial backfill. If the final backfill material contains large rocks (boulder or cobble size) or clumps, then 18" of cushion material should be provided.

Secondary initial backfill may consist of a different material than the primary initial backfill. In all cases, however, it should be a compactable material that is compacted to at least 90% Standard Proctor Density. The major exception to this guideline is when installing pipe where the depth of cover exceeds 24 feet or where the ground water level may rise above the pipe springline. Then it is recommended that the secondary initial backfill be a continuation of the primary backfill.

The final backfill may consist of any material that satisfies road construction or other requirements. The material must be free of large stones or other dense, hard objects which could damage the pipe when dropped into the trench or create concentrated pipe loading. The final backfill may be placed in the trench by machines.

There should be at least 1 foot of cover over the pipe before compaction of the final backfill by the use of self-powered compactors. Construction vehicles should not be driven over the pipe until a 3 foot cover of properly compacted material is placed over the pipe.

When backfilling on slopes, the final backfill should be well compacted if there is any risk of the newly backfilled trench becoming a "French drain." Greater compaction may be achieved by tamping the final backfill in 4" layers all the way from the top of the initial backfill to the ground or surface line of the trench. To prevent water from undercutting the undersides of the pipe, concrete collars keyed into the trench sides and foundation may be poured around the pipe.

MEASURING DEFLECTION

An inherent advantage of Spirolite pipe is that its deflection can be used to monitor the quality of an installation. Unlike rigid pipe, which will temporarily bridge voids or soft spots in the embedment material and delay failure or problems until months after the installation is complete, Spirolite pipe that has been improperly installed will deflect immediately, thus alerting the inspector to the problem. Although the majority of Spirolite pipe installations have only minimal deflection, prudent engineering calls for inspecting the deflection of Spirolite pipe on a routine basis during installation. Inspection should be performed as the job progresses. That way, any errors in the installation procedure can be identified and corrected.

It is suggested that the installer test the first 300-400 feet of pipe after it has been backfilled to verify that the installation design and procedure are adequate. It is also advised that the entire line be checked upon project completion. For this check, wait at least 30 days after installation of a section before deflection testing. This deflection should not exceed 5% of the base I.D. or the engineer's specified deflection, whichever is smaller. (The 5% limit is a construction limit and is not a limit of the pipe's performance. Larger deflections can be tolerated.)

Two methods typically used for measuring backfill are

- Pulling a pre-sized mandrel through the pipe. The mandrel should be sized so that if the pipe exceeds the allowable deflection, the mandrel is blocked.
- Measuring vertical diameters in several places both just before and just after installation of the final backfill.

In order to properly size the mandrel, the allowable vertical diameter of the pipe must be established. This can be calculated by subtracting the allowable deflection from the minimum base I.D. The base I.D. takes into account Spirolite's manufacturing tolerance and any slight ovality that may occur during shipping and handling. The maximum mandrel diameter can be calculated from the following equation:

TABLE 3: BASE I.D.'S OF SPIROLITE PIPE, PER ASTM F -894

$$\text{Maximum Mandrel Diameter} = \text{Base Pipe I.D.} - \left(\frac{Y}{100} \times \text{Base Pipe I.D.}\right)$$

Where:

Y = allowable deflection in percent

$$\text{Base I.D.} = Di - V^2 + B^2$$

Where:

Di = nominal inside diameter of pipe

V = pipe inner diameter manufacturing tolerance (.25")

B = shipping and handling roundness tolerance (Di x .03)

Table 3 shows the Base I.D.'s for all diameters of Spirolite.

Nominal Pipe Size (inches)	Base I.D. (inches)	5% of Base I.D. (inches)
18	17.42	16.55
21	20.34	19.32
24	23.25	22.09
27	26.15	24.84
30	29.07	27.62
33	31.98	30.28
36	34.89	33.15
42	40.72	38.68
48	46.54	44.21
54	52.35	49.73
60	58.18	55.27
66	63.99	60.79
72	69.81	66.32
84	81.45	77.38
96	93.08	88.43
120	119.1	113.5

Many inspectors prefer to directly measure the pipe deflection at several places along the line. The direct method requires measuring the vertical diameter of the pipe after the embedment material has been placed to the crown and compacted. The pipe is then remeasured in the very same place after the final fill has been placed and brought to grade. The difference between the two vertical diameters is the deflection. (See Figure 10, next page.) If this deflection is more than the calculated initial deflection, then compaction must be increased.

TUNNEL AND CASING CONSTRUCTION

Do not attempt to install Spirolite pipe in a casing or tunnel without first reviewing Technical Bulletin TB-140, Grout Encasement for Spirolite Pipe in Casing and Tunnels and ASTM F585, Standard Guide for Insertion of Flexible Polyethylene Pipe into Existing Sewers

Two important considerations whenever Spirolite passes through a tunnel or casing are

- The pipe should be adequately designed or grouted to resist net external hydrostatic pressure if the pipe will be below the ground water table.
- Provisions should be made to accommodate differential settlement which may occur between the flexible pipe and the rigid casing.

Unsupported flexible pipe can collapse if subjected to net external hydrostatic pressure. Net external hydrostatic pressure exists whenever the water pressure outside the pipe exceeds the water pressure inside the pipe. One instance of this occurs when the ground water level rises above a partially full pipe. If the pipe is buried, the

surrounding soil will normally provide adequate support for the pipe. (See Spirolite Technical Bulletin for more information.) However, when a flexible pipe passes through a tunnel or casing pipe that is located beneath the water table, water enters the annulus between the inserted pipe and the casing pipe and exerts a net hydrostatic pressure on the pipe. In this case the pipe must either be designed to resist collapse, or it should be grouted along its entire length to provide support.

FIGURE 10: DETERMINING INITIAL DEFLECTION DUE TO SERVICE LOADS

1. Measure the vertical diameter after embedment has been placed and compacted to pipe crown.

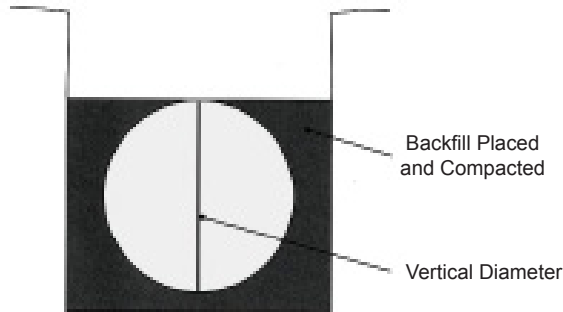

2. After the final backfill has been placed and compacted to grade, remeasure the vertical diameter at the exact location where it was measured in Step 1.

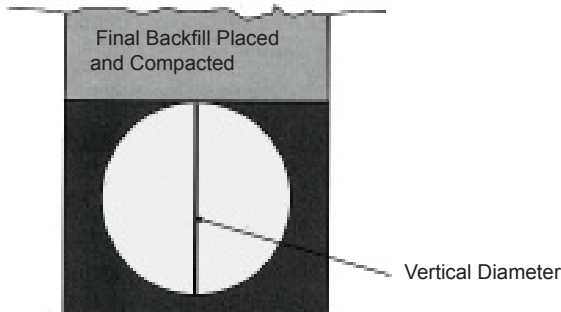

3. Calculate percent deflection using diameters obtained in Step 1 and Step 2.

$$\text{Percent Deflection} = \frac{\text{Step 1 Dia.} - \text{Step 2 - Dia.}}{\text{Step 1 Dia.}} \times 100$$

As illustrated in Figure 11, the Spirolite pipe liner installation trench must accommodate the jacking equipment, the pipe length, and joint assembly clearance. Trench length may be determined from:

The trench or opening should be 3 feet (18" per side) wider than the jacking equipment or the pipe diameter whichever is wider. Depending upon soil stability, shoring, sheeting, or sidewall bracing may be required.

Spirolite pipe sliplining procedure is the same as the OD controlled sliplining procedures except for grout encasement. Basic requirements include cleaning and inspecting the original pipeline, liner installation, making service connections, grouting the annulus if required, and backfilling the point excavations. Cleaning the original pipeline may involve water jet cleaning, powered cutterhead cleaning (power rodding), and/or pigging with various hard or soft pigs. Any obstructions that could interfere with liner passage must be removed.

FIGURE 11. SPIROLITE PIPE LINER INSERTION TECHNIQUE

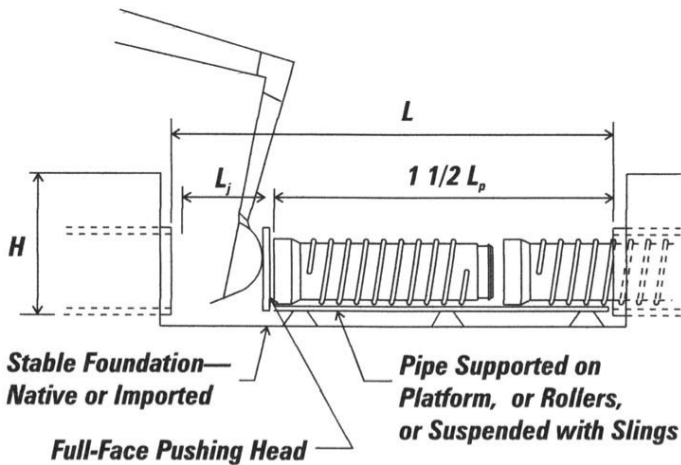

$$L = (L_j + 2) + (1.5L_p)$$

Where:

L = insertion trench length, ft

L_j = jacking (pushing) equipment length, ft

L_p = length of liner pipe, ft (20 ft or 13 ft)

CAUTION: Grouting is a critical process. The liner may see its greatest loads during grouting. The project engineer should provide the installer with a specification for the grouting process. Grout pressure must not exceed the collapse resistance of the liner. Improper grouting can cause liner collapse. See Spirolite TB 140, Grout Encasement for Spirolite Pipe in Casings and Tunnels for general information on grouting

Care must be taken when grouting between Spirolite and the casing to avoid collapsing the Spirolite pipe. Grout pressure can be offset by filling the pipe with water, restraining its ends, and putting a slight head pressure on it. Consult PLASSON USA Technical Services for recommended pressures. In order to reduce the external pressure on the pipe, the grout can be placed in lifts. Care should be taken to protect the pipe from flotation by restraining it during grouting. For long lines, this can be accomplished by placing wood chocks along the pipe crown or using water as a weight when placing the grout in lifts.

After the service connection is completed, the casing to liner annulus must be sealed to prevent backfill migration and the area must be backfilled. The annulus may be sealed with grout, concrete or cement-stabilized Class I or Class II soil. Initial backfill should be with cement stabilized Class I or Class II soils, compacted Class I or Class II soils, or concrete. Care should be taken to ensure the haunch areas are filled and compacted.

Differential settlement may occur between the service pipe and the casing pipe. The situation is similar to a pipe passing through a rigid wall. Methods for reducing differential settlement are discussed in the section on trench bottom preparation, page 19.

JOINING SPIROLITE PIPE-RUBBER GASKET SYSTEM

Spirolite is assembled by a bell and spigot gasketed joint designed to meet ASTM D-3212, *Joints for Drain and Sewer Plastic Pipes Using Flexible Elastomeric Seals*.

The Spirolite gasket protects against both infiltration and exfiltration. The gasket's unique profile provides a compression seal against exfiltration and a compression and hydraulic seal against infiltration. The hydraulic seal is energized by external pressure, becoming tighter with increasing infiltration force. Infiltration rates not to exceed 50 gallons/inch of diameter/mile of pipe/day may be specified for the Spirolite gasket joint.

To achieve this high quality seal, the joints must be properly cleaned, assembled and aligned. Care must be taken during the actual joining of the pipe to ensure that the bell and spigot remain free from dirt and debris.

To help keep the gasket clean, it is advantageous to install the gasket on the spigot in the trench and to place a piece of cardboard directly on the trench bottom at the entrance to the bell so that the spigot doesn't pick up dirt as it is pushed home. This can also be accomplished by providing a shallow hole at the leading edge of the bell.

Also, the gasket must be stress-relieved after it is installed on the spigot. This is most easily accomplished by slipping a smooth object like a screwdriver under the gasket and running it around the circumference two or three times. After equalizing the stretch in this manner, it is necessary to reposition the gasket so that it is properly seated in the groove. ***Failing to equalize stretch or reposition the gasket can result in a leaking joint, so care must be taken to see that these steps are carried out.***

It is also helpful to lay the pipe so that its maximum diameter is oriented vertically. This increases the ease of installation and helps offset service load deflection. To achieve this, the pipe diameter should be checked prior to lowering the pipe into the trench. A carpenter's rule is suggested. Once the maximum diameter has been determined, mark the point on the inside of the pipe with a lumber crayon. This point should be at the bottom of the pipe when it is placed in the trench.

Once the pipe is in the trench, the bell and spigot have been wiped clean, and the gasket is on the spigot, the front of the gasket and the inside surface of the bell must be lubricated. Take care not to allow the lubricated gasket to touch the trench bottom.

Joining small diameter (27" and under) Spirolite pipe can be accomplished using come-alongs and chains around the pipe. When using this method, care must be taken not to damage the ribs when pulling the pipe together.

On larger diameter Spirolite pipe, a mechanical assist such as a backhoe bucket is used to join the pipe. The load is applied to the pipe through a beam (such as a 4 x 4) which is placed across the end of the pipe opposite the end being joined. The bucket is placed against the beam or plate and pushed the pipes together. The beam is used to prevent damage to the pipe and should be placed at the springline of the pipe so that it evenly distributes the pushing load. Failure to properly center the load could result in damage to the pipe.

For limited access applications such as sliplining with Spirolite pipe liner, it is important that the backhoe is applying force parallel to the Spirolite pipe. In certain situations, it may be necessary to use larger beams (6x6 or 8x8), cross brace two beams, full-faced pushing heads or use come-a-longs in combination with a backhoe as described in ASTM F585 to ensure the adequate force is being applied to the Spirolite pipe to bring the pipe home.

In all cases, align the pipe to be coupled as straight as possible and push the pipe into the bell until the edge of the bell meets the homing mark on the spigot. The maximum angular misalignment for proper sealing varies per size between 2° to 3° per size. Plasson USA should be consulted on any projects requiring angular misalignment of the joints.

At job start-up, and at the manholes, it will usually be necessary to block or restrain one end of the first pipe laid to prevent it from moving when the joint is pushed together.

ORIENTING PIPE TO OFFSET SERVICE DEFLECTION

As described above, Spirolite service load deflection can be offset by orienting or strutting the pipe prior to placement in the trench. All flexible pipe possess some inherent out-of-roundness. This is usually of minimal percentage. Often the installer will take advantage of this out-of-roundness to orient pipe so that the long axis is placed in the trench in the vertical direction. When the pipe is backfilled, the deflection due to backfilling is offset by the orientation of the pipe. Orienting pipe should be considered for pipe of 30" and larger diameters.

Often an installer will further offset deflection by placing wood struts inside the pipe. Struts are usually cut from 2 x 4's. This length is typically 3% longer than the nominal pipe diameter. Usually 3 sets of struts are placed in each pipe length. Each set consists of two struts placed in a cross to allow a laser beam to pass between them. Struts should be considered for all projects where the pipe diameter is 42" or larger and the depth of cover is more than 12 feet. Struts must be removed before any backfill is placed above the pipe.

IMPORTANT REMINDERS FOR EFFECTIVE SEALS

- Clean pipe ends prior to joining.
- The gasket must face the correct direction and seat properly in the spigot groove.
- Apply lubricant to the entire spigot groove, exposed gasket surface, and entire inner surface of the bell.
- Use only the recommended lubricant.
- Insert a screwdriver under the gasket and run it around the circumference two or three times.
- Ensure bell and spigot is properly aligned
- Always use a wooden member between any mechanical pushing device and the pipe end.
- The spigot is not completely seated until it is in the "home" position in the bell.

PROCEDURE FOR SPIROLITE GASKET AND JOINT ASSEMBLY

PLASSON USA provides gaskets and lubricant for joint assembly. One profile gasket is supplied for each length of Spirolite pipe. They ship separately and must be installed on the pipe just prior to installation of the line. Use the following procedure for Spirolite joint assembly.

1. Prior to positioning of the gasket into the groove in the pipe spigot, wipe the entire spigot end clean of all dirt and other foreign material.
2. Apply a liberal coating of lubricant to the entire spigot groove (see figure 12). Use only the PLASSON USA provided lubricant for joint assembly, or a lubricant approved by the Project Engineer that will not detrimentally affect the pipe or gasket materials.
3. Thoroughly clean gasket and place it into the lubricated spigot groove by starting at the bottom and working up. Make sure that the gasket fins face back toward the pipe. Apply a liberal coating of lubricant to its entire surface.
For the joint to be an effective seal, the gasket must be mounted in the proper direction. (See Figure 13.)
4. Insert a smooth object such as a screwdriver under the gasket and run it around the circumference two or three times. This equalizes the stretch in the gasket. After equalizing stretch, reposition the gasket in the groove so that it is properly sealed all around. ***Failure to equalize the stretch or to properly reposition the gasket can cause leaks in the joint or cause the gasket to break.***
5. Thoroughly clean the inside surface of the matching bell pipe and apply the recommended lubricant to this entire surface.
6. Align the pipe to be coupled as straight as possible to the receiving bell, and, making sure no dirt or other debris is allowed to touch the mating surfaces, push the pipe into the bell until it is “home.” The “home” position is indicated when not more than approximately 1/2” of the machined spigot surface is visible outside the bell. To push the pipe into the bell, apply a mechanical assist to the end of the pipe opposite to the end being assembled. Use a piece of wood capable of spanning the pipe diameter between the mechanical assist and the pipe. This is necessary to prevent damage to the pipe end and to provide even distribution of the pushing load.

**FIGURE 12:
LUBE REQUIRED PER JOINT**

SIZE	LBS/ JOINT	GAL/ JOINT	SIZE	LBS/ JOINT	GAL/ JOINT
18	0.59	0.07	48	1.58	0.20
21	0.69	0.09	54	1.78	0.22
24	0.79	0.10	60	1.98	0.25
27	0.89	0.11	66	2.18	0.27
30	0.99	0.12	72	2.38	0.30
33	1.09	0.14	84	2.77	0.35
36	1.19	0.15	96	3.17	0.40
42	1.39	0.17	120	3.96	0.50

**FIGURE 13:
CORRECT PLACEMENT OF GASKET**

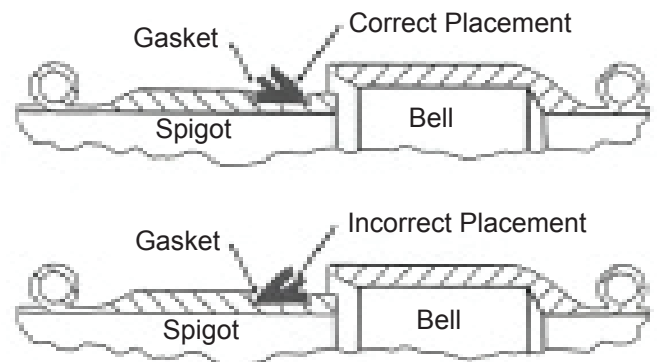





www.PlassonUSA.com

305 N 7th St., Corsicana, TX 75110 | 800-241-4175

Stafford, TX | Corsicana, TX

Our fittings meet the strictest specifications.



AMERICAN PETROLEUM INSTITUTE

