



Spirolite

TECHNICAL BULLETIN

Grout Encasement For
Spirolite Pipe in Casings and Tunnels



www.isco-pipe.com

GROUT ENCASEMENT | CASINGS AND TUNNELS



Spirolite pipe is often used as a carrier pipe installed in tunnels or casings. The annular space between the Spirolite pipe and the casing needs to be filled. Filling helps maintain grade, alignment, and joint integrity. Filling resists flotation and

the external fluid pressure on the pipe when ground water exists in the casing. Grouting is also capable of eliminating voids just outside the host pipe.

Caution: Grouting is a critical process. The carrier pipe may see its highest loads during grouting. The project design engineer should provide the contractor with a specification for the grout to be used.

GENERAL REQUIREMENTS

The proper pipe class for a grouted encasement will depend on the specific application including depth of cover and length of grouted pipe. The selected class should be shown to safely withstand the applied grout pressure, ground water pressure, and any other service load.

Water present in the casing needs to be removed prior to grouting. After placing the Spirolite pipe in the casing, the water level in the casing needs to be maintained below the Spirolite invert until the grout develops sufficient strength to support the pipe. Blocking the liner to prevent floatation during placement of the grout may be necessary (see Fig. 1 & 2).

The project engineer should specify a grout strength adequate to support the pipe for all anticipated loadings. In addition, the grout must have a low enough viscosity that it will flow from one end of the casing to the other.

The slope (grade) of the casing needs to be controlled so that only minor adjustments will be required to bring the Spirolite to grade. Differential settlement may occur between the pipe and casing unless the casing is properly embedded.

PREPARATION FOR PIPE INSERTION

Generally, pits need to be excavated at each end of the tunnel or casing to permit pipe. The jacking pit needs to be of sufficient length to allow pushing room for the backhoe bucket.

Prior to insertion of Spirolite pipe, pump out the water in the casing so that there is not more than a few inches of water remaining. This small amount of water will help reduce friction to facilitate the insertion procedure.

FILLING WITH WATER

In order to assist in countering the buoyancy effect of the grout and to resist excessive deflection, it is beneficial to fill the section of Spirolite pipe with water. When water is not used the project design engineer should verify that the external blocking system and the internal bracing are sufficient to resist deflection due to the buoyant force of the grout.

The line can be blocked off on both ends with pneumatic plugs, or other suitable means strong enough to resist the horizontal pressure from the water.

BLOCKING AND BRACING IN LIEU OF FILLING WITH WATER

The slope of Spirolite pipe can be maintained by placing centering blocks or skids around the pipe (see Fig. 1, pg. 2). This technique is especially suited for 36" or smaller pipe. Skids can be held on the pipe by banding or wire. Skids typically consist of 2x4's or boards that have been cut to the right width to properly center pipe in the casing.

Fig. 1

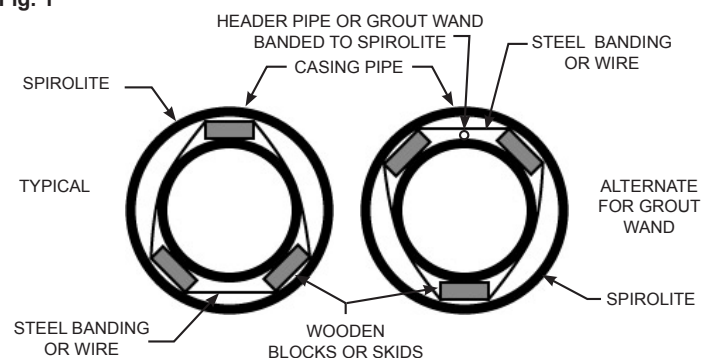

ARRANGEMENTS FOR SKIDS OR BLOCKS ATTACHED TO PIPE

Fig. 2

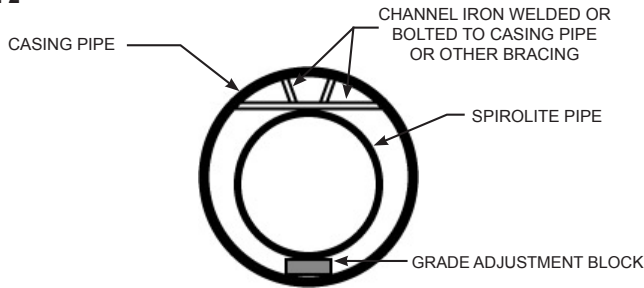

TYPICAL FIXED RESTRAINING SYSTEM ATTACHED TO CASING

Typically skids are two feet long. Place at least two sets per pipe section. The exact skid size will depend on the casing diameter, the pipe diameter, and the clearances. Skids can be placed at the crown and haunches, 120 degrees apart as viewed on the pipe cross section. The two lower skids will maintain grade while the upper skid will help prevent the pipe from rising off grade due to flotation. Centering the pipe with skids in the casing is the best method of maintaining proper grade and alignment during pouring of the grout. Note that the upper skids need to have sufficient structural integrity to resist the buoyant force created.

Another method of centering and alignment is to place continuous blocking at the top of the carrier pipe (see figure 2). This blocking needs to be strong enough to resist the buoyancy force exerted by the grout on the pipe. This method is typically used for larger diameter pipe over 36”.

INTERNAL BRACING Grout creates an upward force on the pipe which can cause upward deflection of the pipe’s invert. Struts need to be designed to resist this force. Internal bracing is typically used with Spirolite pipe during the grouting (see Fig. 3), to resist upward vertical deflection during the grouting process. The bracing needs to be continuous along the entire length of the encasement. Typically 4x4’s are placed along the crown and invert of the pipe with vertical struts every three feet. Bracing may be placed in the pipe either before or after the pipe has been inserted in the casing, but should not be removed until the last lift of grout has set.

INSERTING THE PIPE

Place the first length of pipe into the jacking pit. Slide the pipe into the casing but leave about two feet of the bell end extending out of the casing. This piece of pipe must be held in order to allow the joint with the next piece of pipe to be made. This joint can be assembled using a come-a-long. Alternatively, the pipe in the casing can be blocked, thus allowing the connection to be made in the normal manner with the backhoe. Please refer to Spirolite Technical Bulletin No. TB-914 for more detailed joining recommendations.

Place the next length of pipe in the trench and assemble the joint according to the Spirolite installation instructions. After the joint has been assembled, remove any blocks, chains, or cables that were used to hold the first pipe in place. Push pipe with the backhoe into the casing until the next bell is two feet from the casing. Repeat this joining procedure until all of the pipe has been placed inside of the casing.

A final joint must be made to connect the pipe in the casing to the pipe that had previously been installed in the trench. This joint can be assembled by pushing with the backhoe bucket. When this method is not adequate, come-a-longs may be used to assist the connection. Connector pieces may be provided for special assembly conditions.

PREPARATION FOR GROUTING

Construct a bulkhead or packer at both ends of the casing pipe so that the annulus is blocked off and can be filled with the grout mix. Typically, air bleed valves are provided at both ends of the line. The number and height of the lifts needs to be calculated by the project design engineer according to the mix

Fig. 3

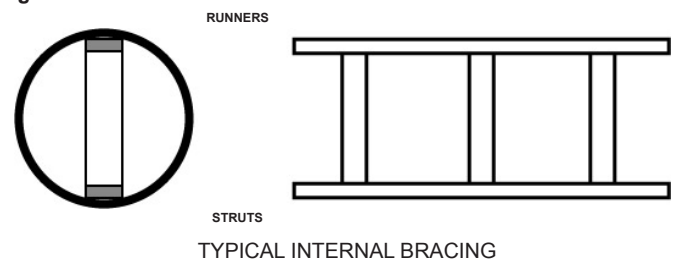

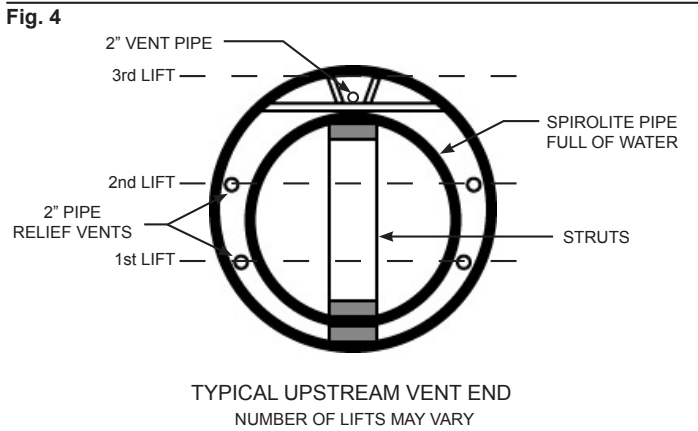

and density of the grout and allowing an adequate safety factor for the hydrostatic collapse resistance of the Spirolite pipe (see Fig. 4). Many applications, particularly with large diameter pipe, require more than one lift. Place a relief vent in the bulkhead on the upstream end at the specified height of each lift of grout.

GROUTING

Caution: Exceeding the pipe's allowable collapse pressure could cause buckling and excess deflection.

Due to the variation of RSC'S available (Ring Stiffness Constant) standard grouting pressures should be limited to no more than to 2 psi. Groundwater and hydrostatic pressures at the liner may not be the same as measured at the grout pump.

The grout pressure in the annular space should not exceed the pipe's allowable collapse pressure. (The grout pressure applied to the pipe is usually equal to the static head pressure of the grout measured from the elevation at the bottom of the lift.) Where the annular space of the casing is sealed off at the ends prior to grouting, an open ended stand pipe needs to be installed with its height such that the grout pressure cannot exceed the pipe's collapse pressure. The project engineer should review the grout placement procedure with particular attention to the grouter's method of controlling and monitoring the grout pressure. Normally, filling the Spirolite pipe with water counteracts the grout pressure.

Usually casings are short enough that no head pressure above that of the casing crown is required to fill the annular space. The safest approach is to pour grout into the casing rather than pump it.

Typically, grout is poured from the downstream end. The grout hose should not be placed inside the casing. (If the annular space were to become blocked, pressure equal to the column of grout in the hose would develop and this pressure could damage the pipe.) Therefore, the grout must be allowed to drop from the end of the hose into the casing. This can be done by constructing a sled, splashboard, or puddling area at the top of the downstream bulkhead. Once grout runs out of the upstream relief vent, grouting for that lift should cease. The next lift should not be performed until the previous lift has set. Each lift can be checked by calculating the annular volume and comparing that to the quantity of grout consumed.

If necessary, grout can be pumped through a grout wand which is small diameter hose or plastic pipe placed in the annular space between the Spirolite pipe and the casing. (Care needs to be taken not to develop a fluid pressure in the annular space.) As the grout is pumped the grouting wand may be removed. A separate wand is required for each lift.

Another option is to band the grout wand to the Spirolite pipe. Typical grout wands are 1 1/2"-2" with "Tees" placed at five foot intervals.

After grout installation is complete, care needs to be taken to carefully place embedment material around the pipes in the bore pits. Placement and compaction have to be done from the trench wall to ensure deflection control of the Spirolite pipe.

This bulletin is intended to be used as a guide to aid the project design engineer in the use of Spirolite pipe. It is not intended to be used as installation instructions, and should not be used in place of a professional design engineer. The information contained herein cannot be guaranteed because the conditions of use are beyond our control. The user of this bulletin assumes all risk associated with its use.