

**14" AND LARGER  
RESILIENT WEDGE VALVES KS-RW**

KENNEDY VALVE

**KENNEDY VALVE AWWA Resilient Wedge Gate Valves  
Meet or Exceed the Requirements of  
AWWA Standard C515**

Size Range	Water Working Pressure psi	Bubble Tight Test psi	Hydrostatic Shell Test psi
AWWA 14"-24"	250	250	500
ULFM 14"-16"	200	200	400

**Available in either non-rising stem or outside screw & yoke.**

<b>Available End Connections &amp; Size Range</b>	<b>Figure No.</b>
FLG End (NRS) 14"-24"	7561SS
M.J. 14"-24"	7571SS
FLG & M.J. 14"-24"	7572SS
FLG End (OS&Y) 14"-24"	7566SS
M.J. for Tapping 14"-24"	7950SS
Tyton for D.I. & C900 PVC 16"	7901SS

**Note: 18" and larger valves require gearing**

Accessories

Indicator Posts	2" sq. Operating Nuts
Enclosed Gearing (14"-24")	Handwheels
"T" Handles	Extension Stems
Stem Guides	Floor Boxes
Electric Motor Actuators	Chain Wheels

Floorstands (non-rising stem)

MODEL KS-RW/2638 AWWA C515 REDUCED WALL DUCTILE IRON

Complies with applicable requirements of AWWA C515

**14"-24" R/W VALVE  
NRS ASSEMBLY MATERIAL LIST**

KENNEDY VALVE

MODEL KS-RW/2638

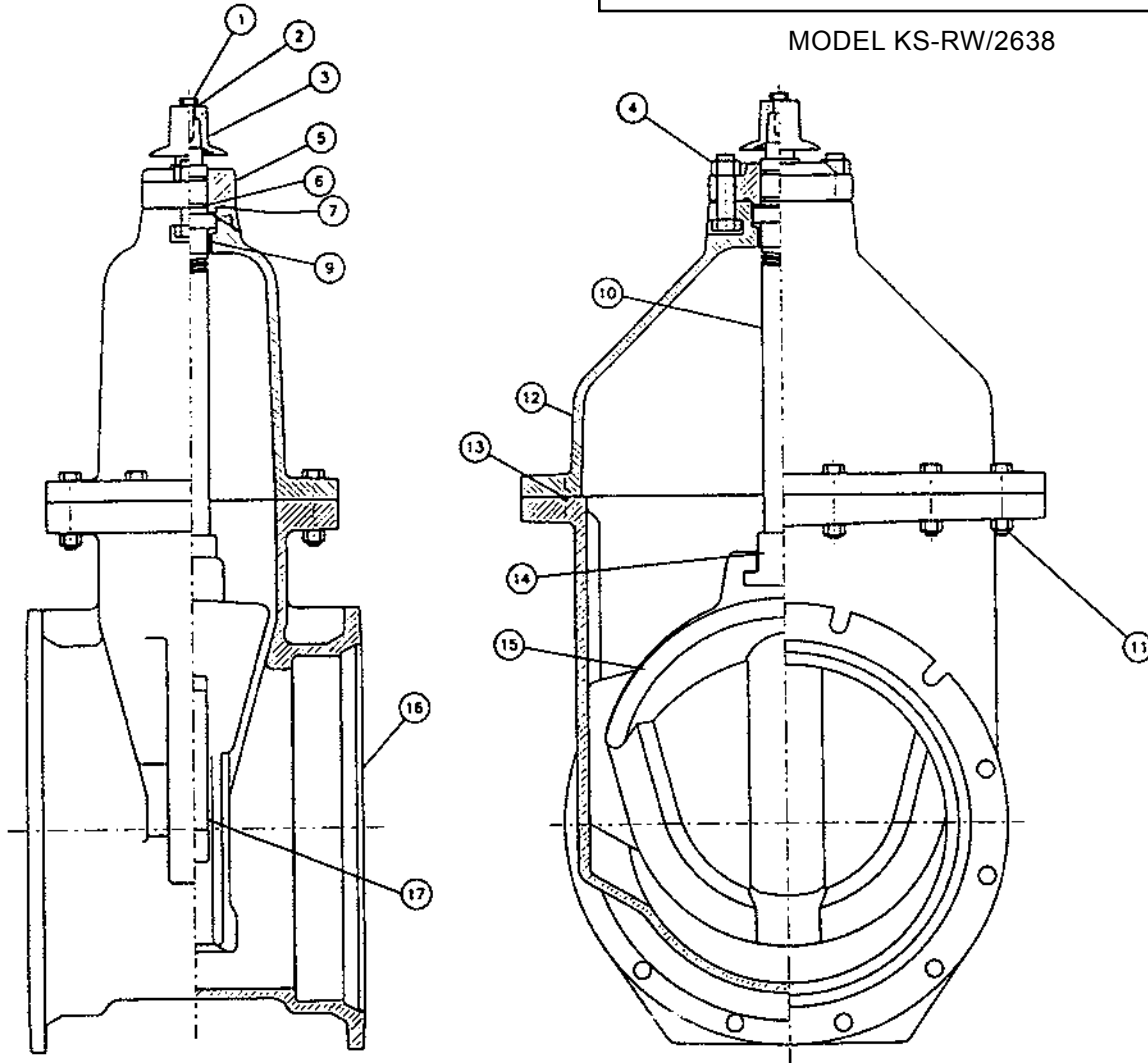

ITEM	DESCRIPTION	MATERIAL	ASTM SPEC.
1	HEX HEAD BOLTS	STAINLESS STEEL	ASTM F593-304
2	FLAT WASHERS	STAINLESS STEEL	ASTM F593-304
3	OPERATING NUT OR HANDWHEEL	CAST IRON	ASTM A126 CLASS B
4	HEX HEAD BOLTS & NUTS	STAINLESS STEEL	ASTM F593-304
5	FOLLOWER PLATE	DUCTILE IRON	ASTM A536 GR.64-45-12
6	STEM O-RING	BUNA - N	-----
7	FOLLOWER PLATE O-RING	BUNA - N	-----
9	BONNET BUSHING	BRONZE	ASTM B584 CDA 836
10	STEM	BRONZE	ASTM B584 CDA 867
11	HEX HEAD BOLTS & NUTS	STAINLESS STEEL	ASTM F593-304
12	COVER	DUCTILE IRON	ASTM A 536 65-45-12
13	COVER O-RING	BUNA - N	-----
14	STEM NUT	BRONZE	ASTM B584 CDA 836
15	WEDGE	DUCTILE IRON	ASTM B536 65-45-12 EPDM
16	BODY - ALL TYPES	DUCTILE IRON	ASTM A536 65-45-12
17	WEDGE PROTECTOR CAP-18" THRU 24"	DELTRIN	-----

Complies with applicable requirements of AWWA C515

**14"-16" R/W VALVE FLANGED ENDS  
GENERAL DIMENSION**

KENNEDY VALVE

MODEL KS-RW/2638

7561SS

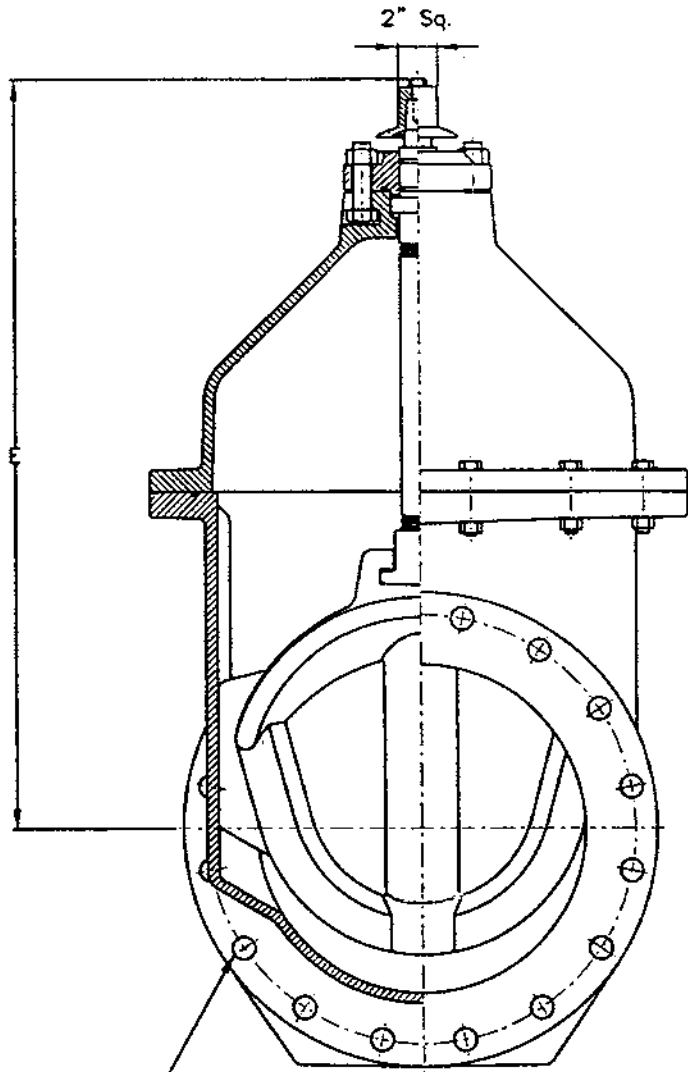
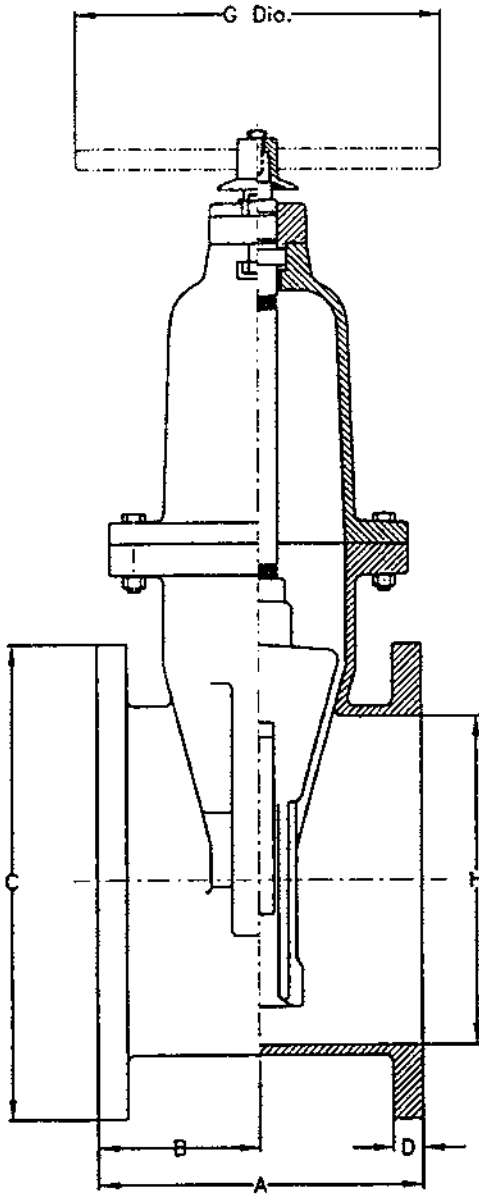

F No. & size of bolts  
Drilling per ANSI B16.1 class 125

ALL FLANGE VALVES ARE TAPPED & PLUGGED @ POSITION "A"

VALVE SIZE		A		B		C		D		E		F		G		H		
inch	mm	inch	mm	inch	mm	inch	mm	inch	mm	inch	mm	#	inch	mm	inch	mm	inch	mm
14	360	15	381	7 1/2	191	21	530	1 3/8	30	37 3/4	959	12	1	25.4	26	660	14 1/4	360
16	410	16	406	8	203	23.5	600	1 7/16	37	37 3/4	959	16	1	25.4	26	660	16 1/4	410

Complies  
AWWA C515

**14"-24" R/W VALVE FLANGED END  
BEVEL GEAR GENERAL DIMENSIONS**

KENNEDY VALVE

MODEL KS-RW/2638

7561BMSS

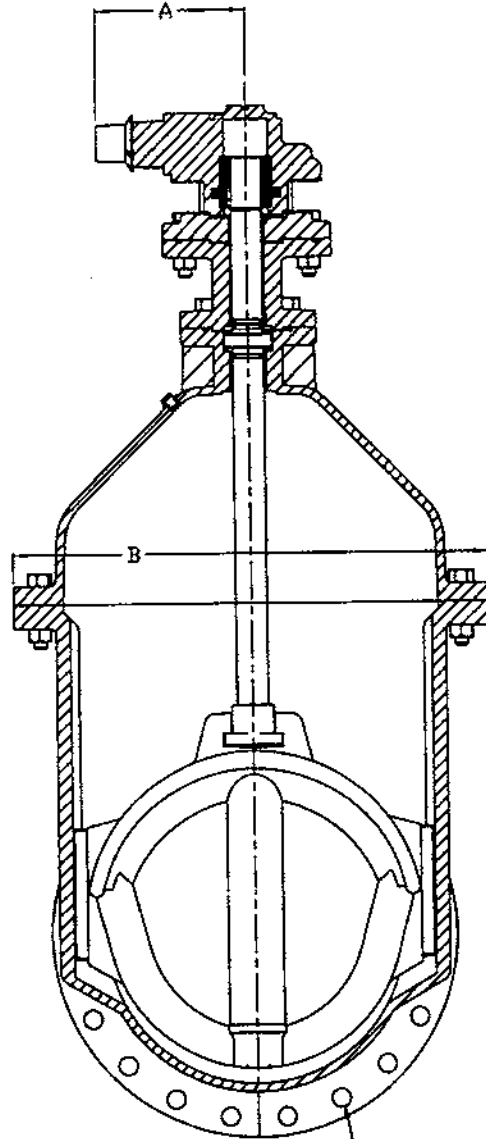
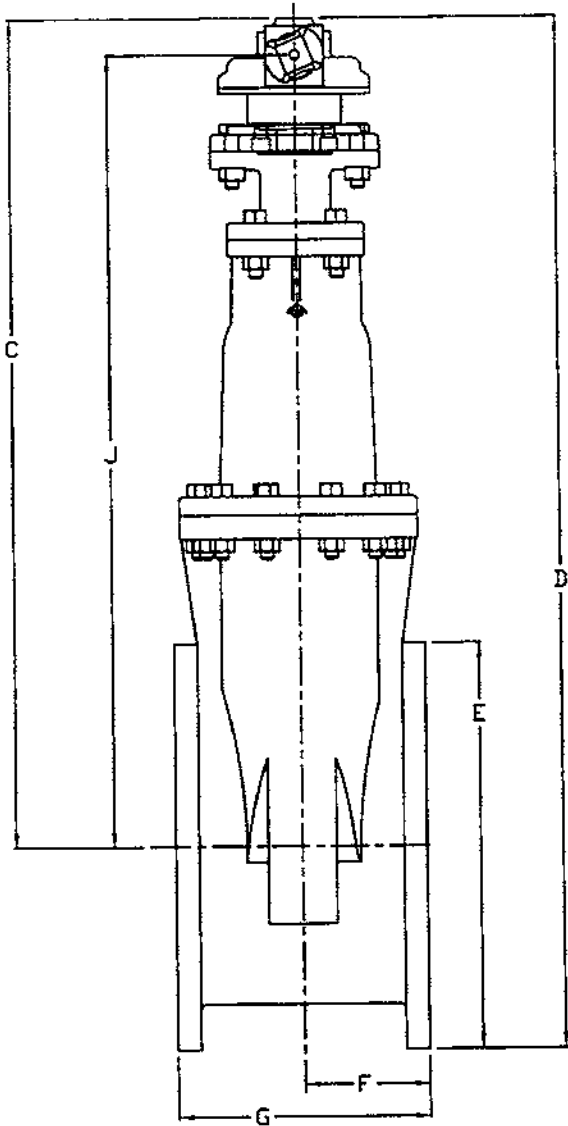

H- No. & size of bolts  
Drilling Per ANSI B16.1  
Class 125

VALVE SIZE	A	B	C	D	E	F	G	H	J
14	9 1/8	26 11/16	48 5/8	59 1/2	21	7 1/2	15	12-1	46 3/8
16	9 1/8	26 11/16	47 5/8	59 1/2	23 1/2	8	16	16-1	45 3/8
*18	10 1/8	32 1/4	55 3/4	68 1/4	25	8 1/2	17	16-1 1/8	55 3/4
*20	10 1/8	32 1/4	54 3/4	68 1/4	27 1/2	9	18	20-1 1/8	52 3/4
**24	10 1/8	36 1/2	60 3/8	76 1/4	32	10	20	20-1 1/4	57 7/8

\*18" AND LARGER SIZES REQUIRE GEARING

\*\*24" ARE NOW FURNISHED WITH ROLLERS, TRACKS, AND SCRAPERS.

(see dimensions on page 6-5 for new installation)

24" R/W RTS BEVEL GEAR FLANGE  
ENDS GENERAL DIMENSIONS

KENNEDY VALVE

MODEL KS-RW/2638

7561BMSS

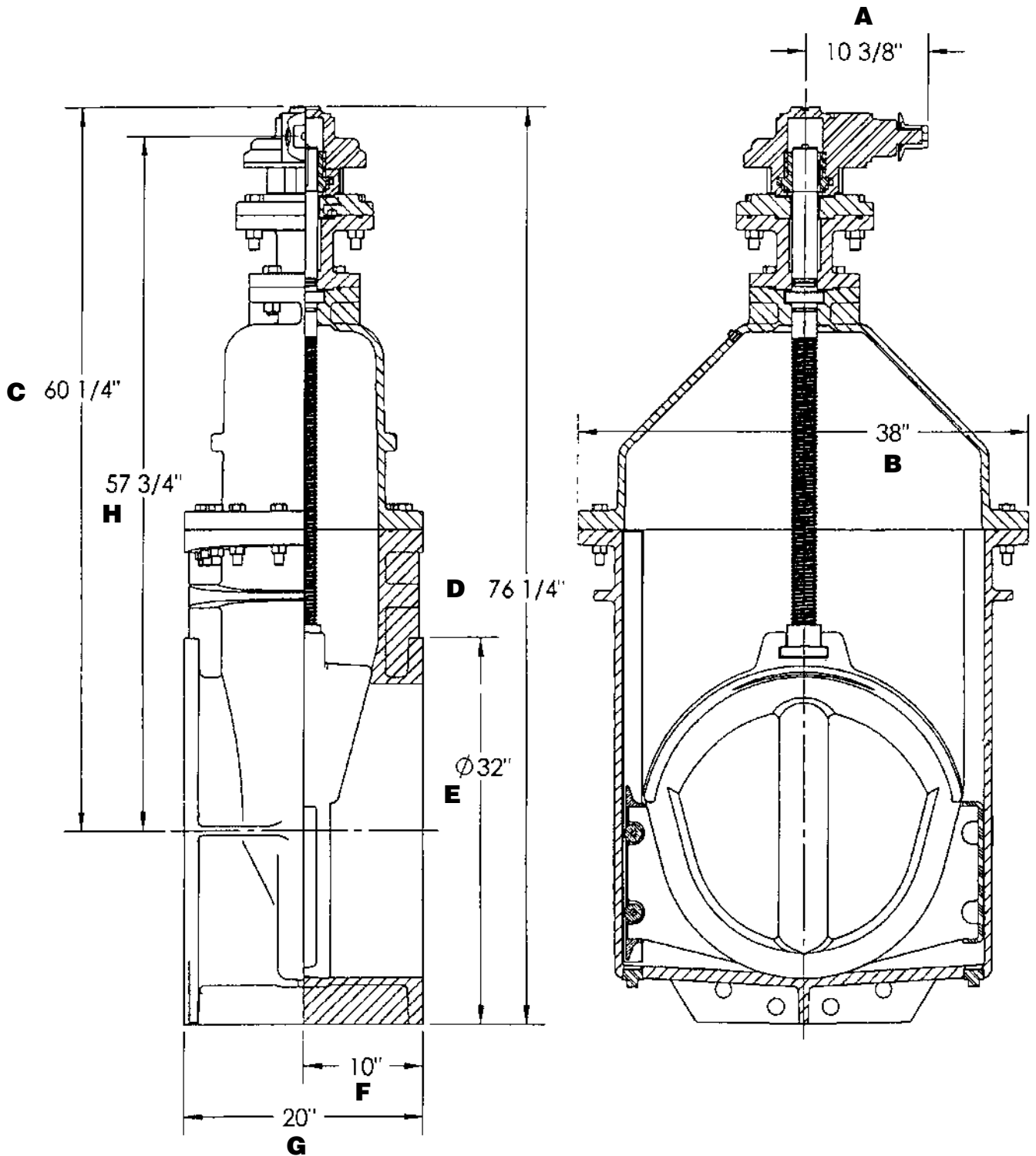

Complies with  
AWWA C515

**14"-24" R/W VALVE FLANGE  
SPUR GEAR GENERAL DIMENSION**

KENNEDY VALVE

MODEL KS-RW/2638

7561AMSS

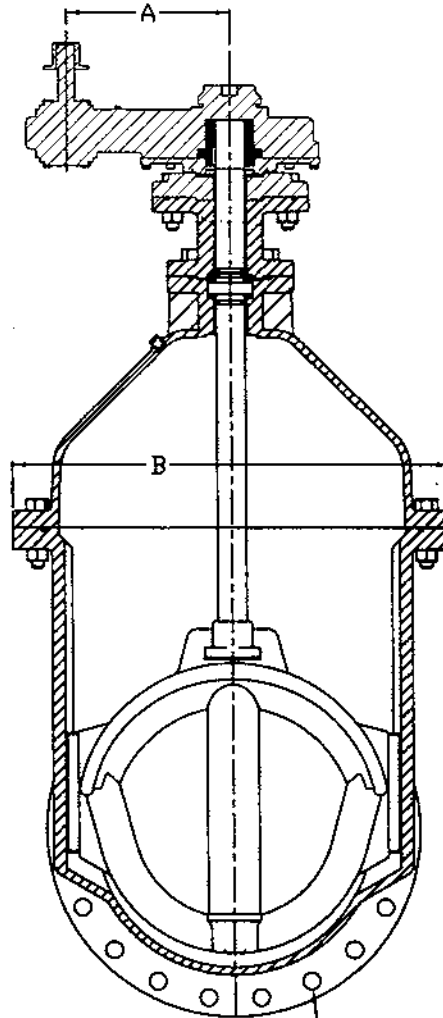
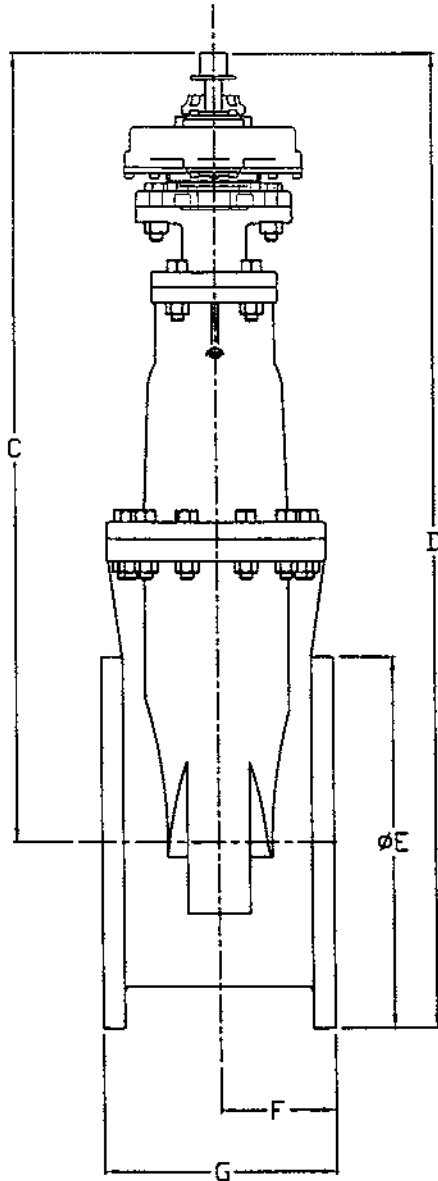

H - No. & size of bolts  
Drilling per ANSI B16.1  
Class 126

VALVE SIZE	A	B	C	D	E	F	G	H
14	8	26 11/16	52 1/8	63	21	7 1/2	15	12-1
16	8	26 11/16	51 1/8	63	23 1/2	8	16	16-1
*18	12	32 1/4	58	70 1/2	25	8 1/2	17	16-1 1/8
*20	12	32 1/4	57	70 1/2	27 1/2	9	18	20-1 1/8
**24	12	36 1/2	62 5/8	78 1/2	32	10	20	20-1 1/4

\*18" AND LARGER SIZES REQUIRE GEARING

\*\*24" ARE NOW FURNISHED WITH ROLLERS, TRACKS, AND SCRAPERS.

(see dimensions on page 6-5 for new installation)

**24" R/W RTS SPUR GEAR FLANGE  
ENDS GENERAL DIMENSIONS**

KENNEDY VALVE

MODEL KS-RW/2638

7561AMSS

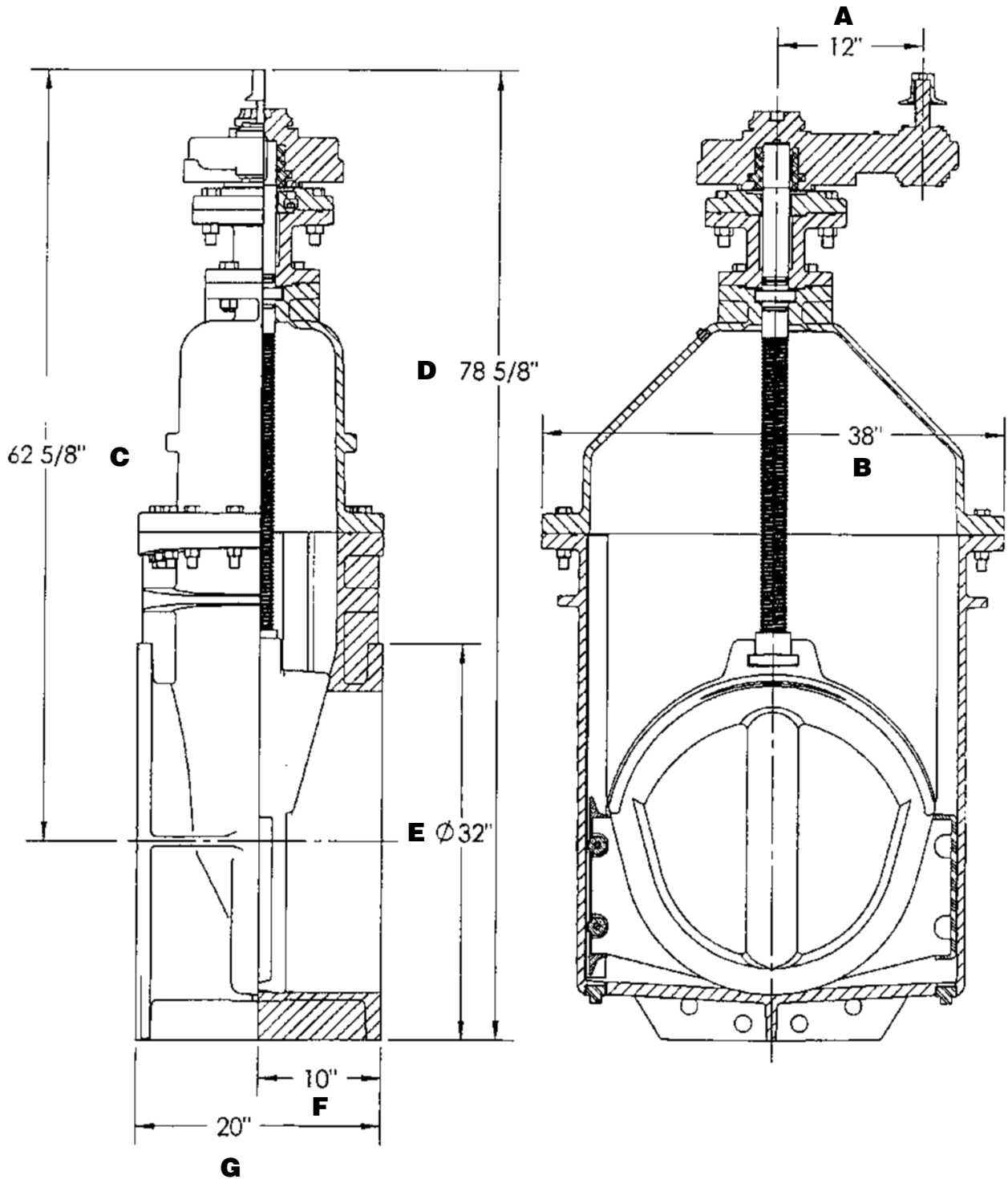

Complies with applicable requirements of AWWA C515

**14"-16" R/W VALVE MJ ENDS  
GENERAL DIMENSION**

KENNEDY VALVE

MODEL KS-RW/2638

7571SS

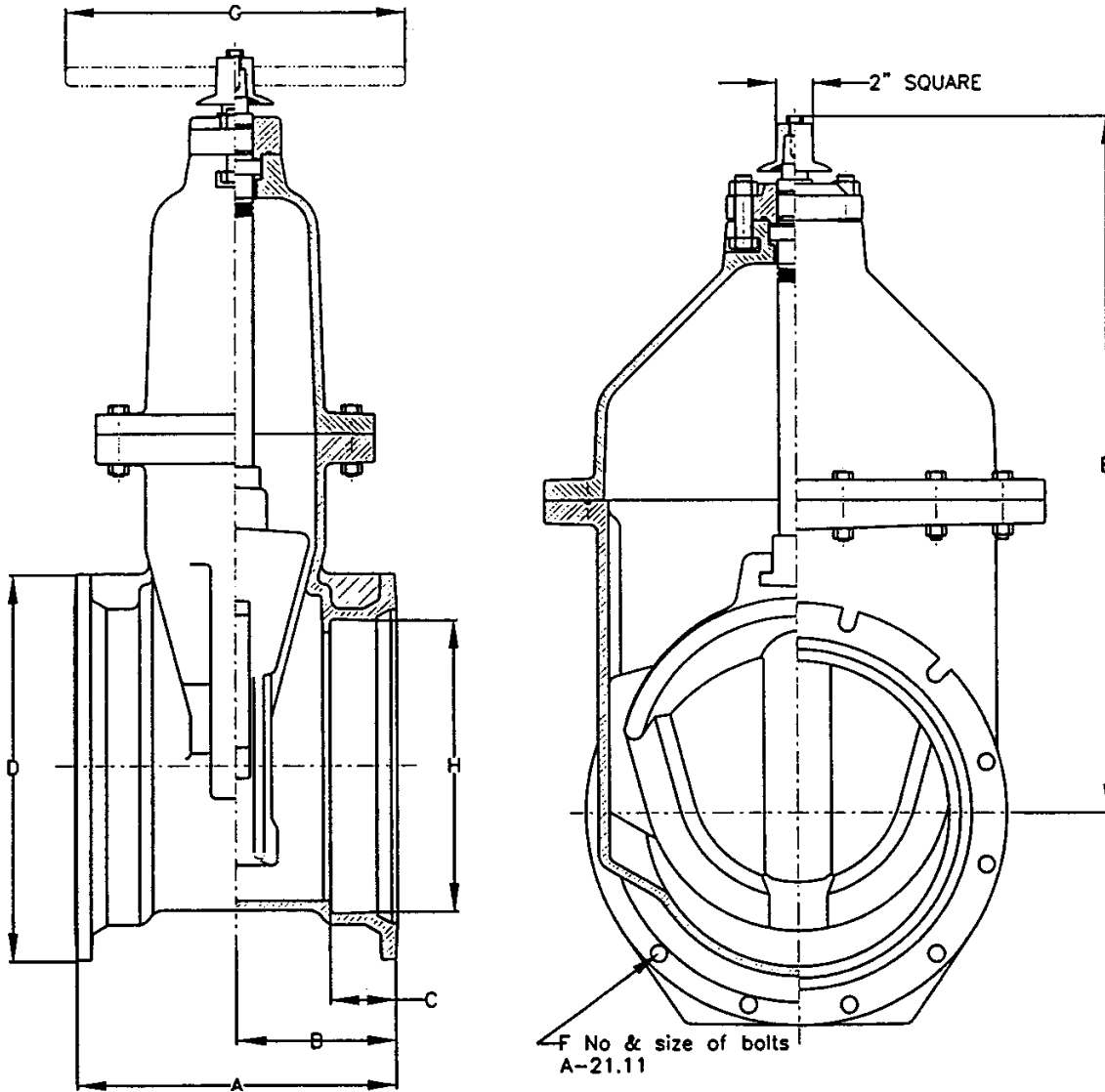

VALVE SIZE	A	B	C	D	E	F	G	H
14	17	8.5	3.5	20.25	37.75	10 3/4	18	14 1/4
16	17	8.5	3.5	22.5	37.75	12 3/4	18	16 1/4



Complies  
AWWA C515

**14"-24" R/W VALVE MJ END  
BEVEL GEAR GENERAL DIMENSIONS**

KENNEDY VALVE

MODEL KS-RW/2638

7571BMSS

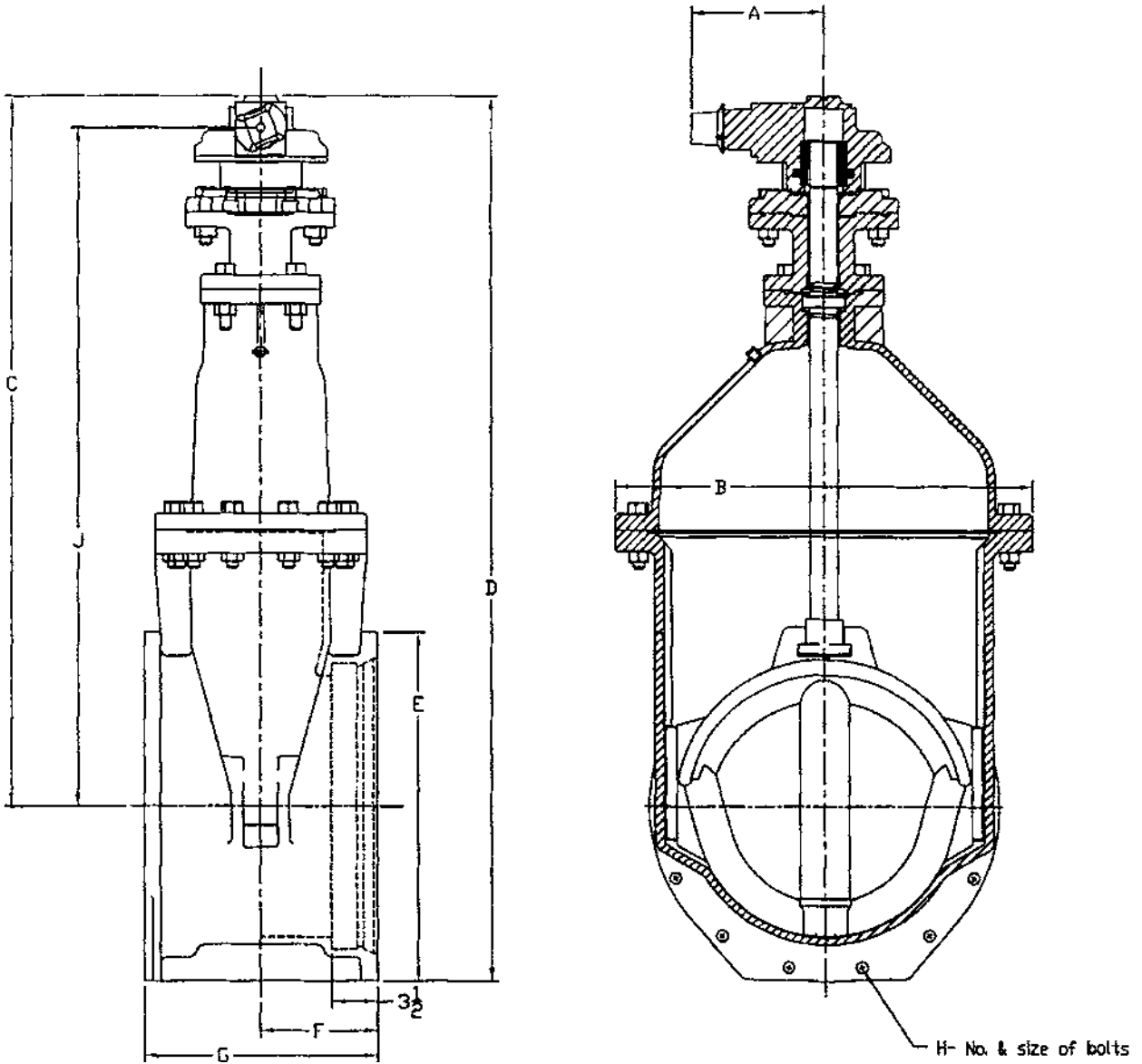

VALVE SIZE	A	B	C	D	E	F	G	H	J
14	9 1/8	26 11/16	48 5/8	59	20 1/4	8 1/2	17	10-3/4	46 5/8
16	9 1/8	26 11/16	47 5/8	59	22 1/2	8 1/2	17	12-3/4	45 5/8
*18	10 1/8	32 1/4	55 3/4	68 1/4	24 3/4	9 5/32	18	12-3/4	53 3/4
*20	10 1/8	32 1/4	54 3/4	68 1/4	27	9 5/32	18	14-3/4	52 3/4
**24	10 1/8	36 1/2	59 7/8	75 1/8	31 1/2	9 1/2	19	16-3/4	57 3/8

\*18" AND LARGER SIZES REQUIRE GEARING  
\*\*24" ARE NOW FURNISHED WITH ROLLERS, TRACKS, AND SCRAPERS.  
(see dimensions on page 6-10 for new installation)

**24" R/W RTS BEVEL GEAR MJ ENDS  
GENERAL DIMENSIONS**

KENNEDY VALVE

MODEL KS-RW/2638

7561BMSS

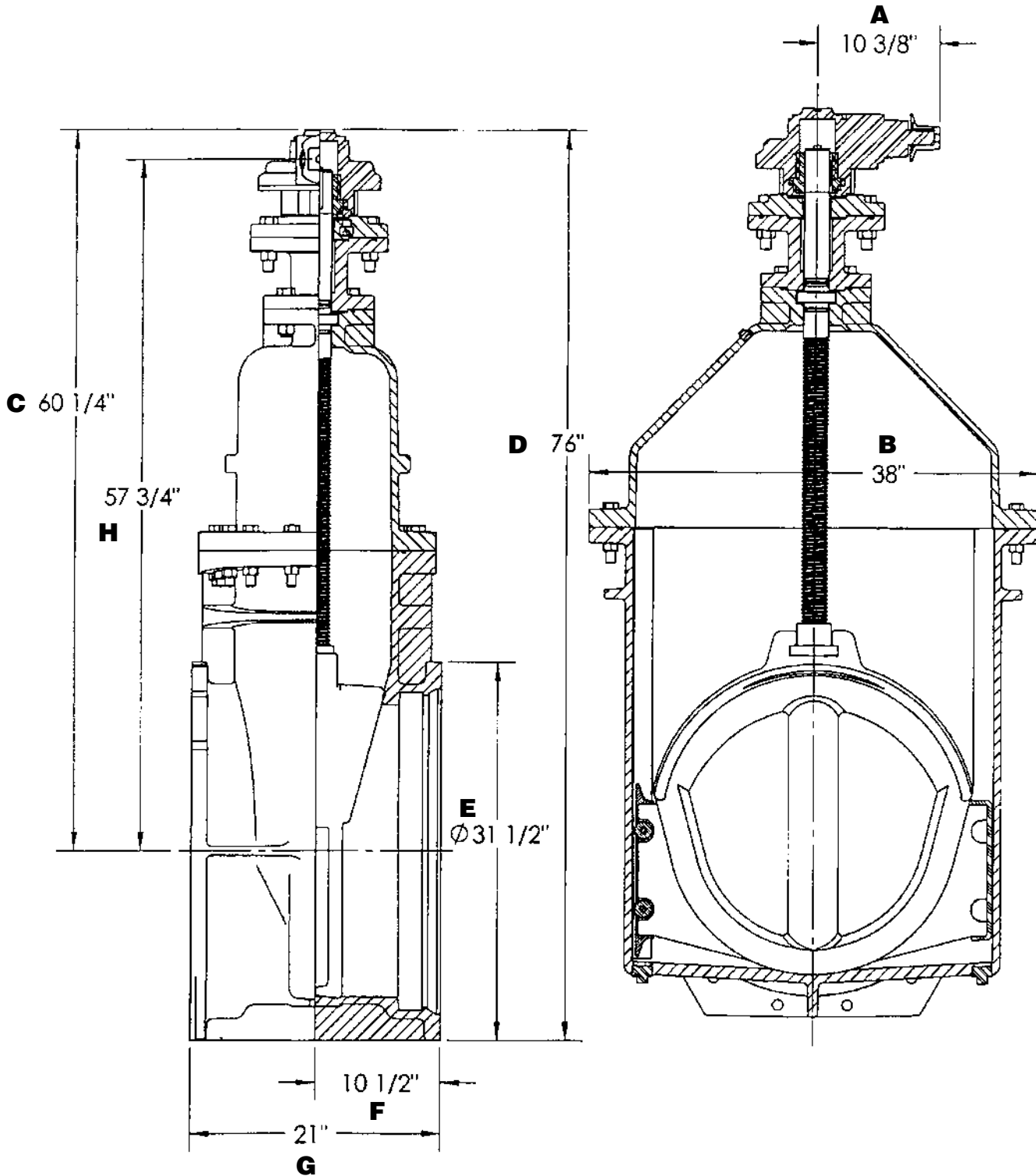

Complies  
AWWA C515

**14"-24" R/W VALVE MJ END  
SPUR GEAR GENERAL DIMENSIONS**

KENNEDY VALVE

MODEL KS-RW/2638

7571AMSS

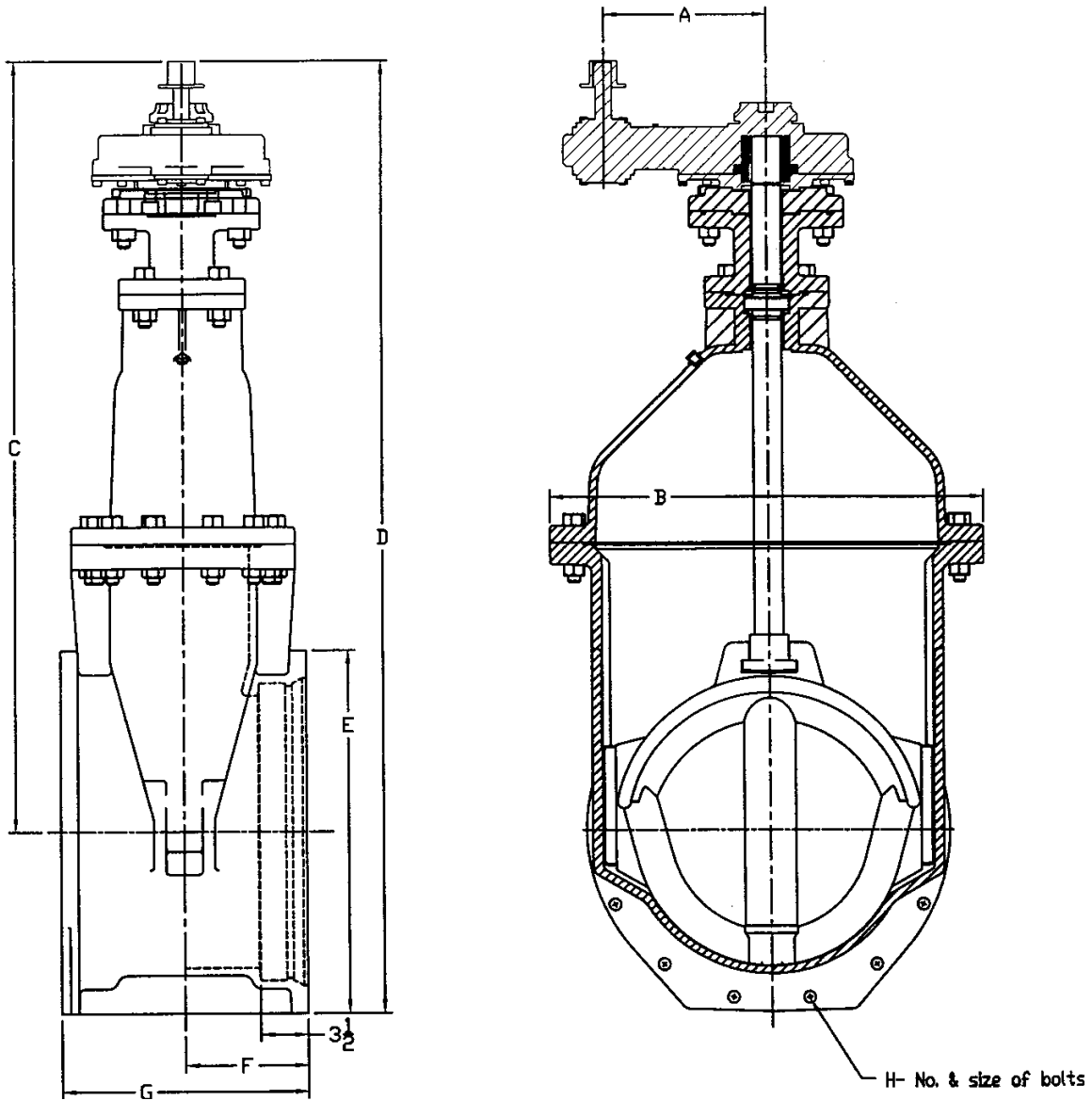

VALVE SIZE	A	B	C	D	E	F	G	H
14	8	26 11/16	52 1/8	62 1/2	20 1/4	8 1/2	17	10-3/4
16	8	26 11/16	51 1/8	62 1/2	22 1/2	8 1/2	17	12-3/4
*18	12	32 1/4	58	70 1/2	24 3/4	9 5/32	18	12-3/4
*20	12	32 1/4	57	70 1/2	27	9 5/32	18	14-3/4
**24	12	36 1/2	62 1/8	77 3/8	31 1/2	9 1/2	19	16-3/4

\*18" AND LARGER SIZES REQUIRE GEARING  
 \*\*24" ARE NOW FURNISHED WITH ROLLERS, TRACKS, AND SCRAPERS.  
 (see dimensions on page 6-12 for new installation)

**24" R/W RTS SPUR GEAR MJ ENDS  
GENERAL DIMENSIONS**

KENNEDY VALVE

MODEL KS-RW/2638

7571AMSS

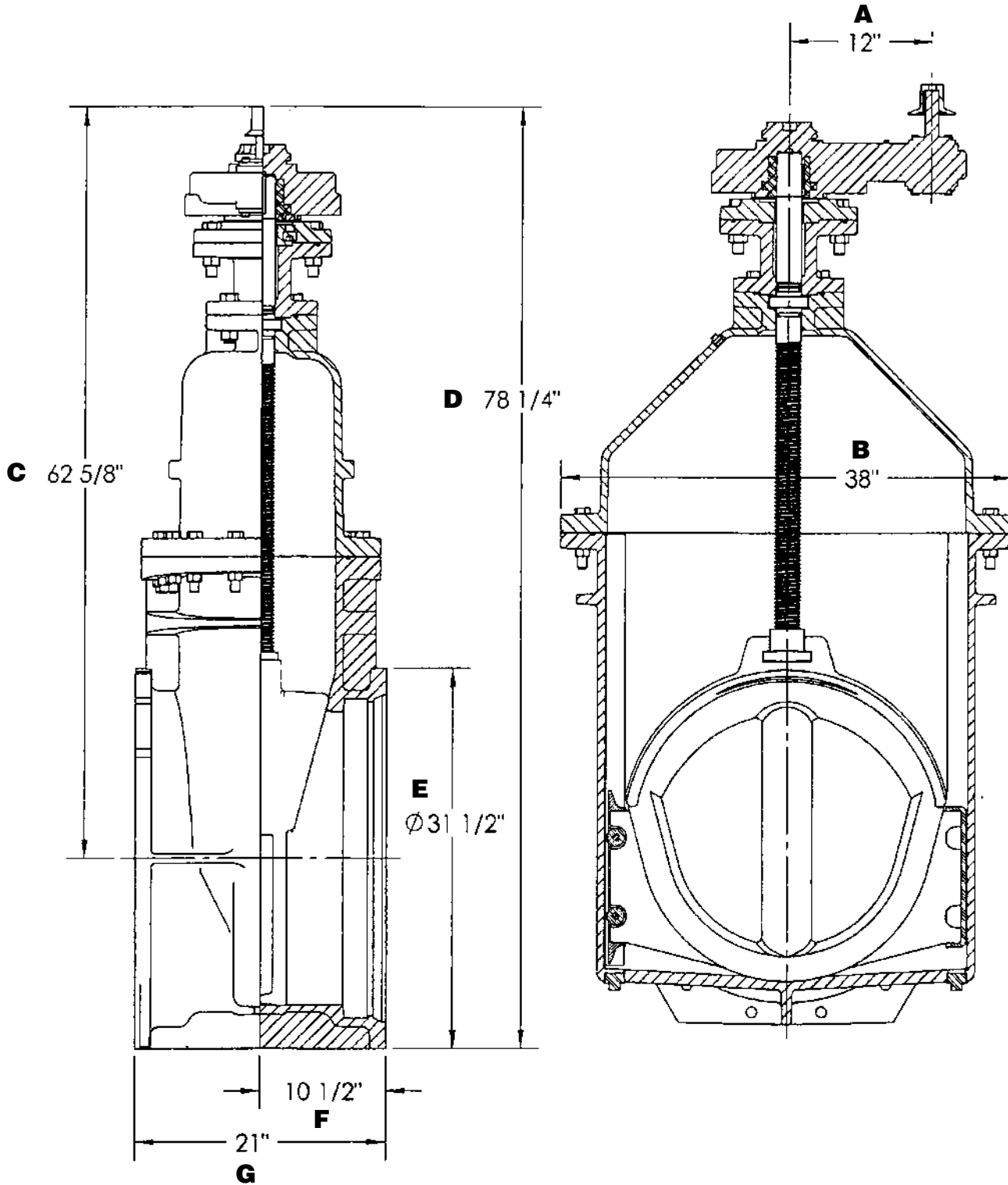

Complies with applicable requirements of AWWA C515

**14"-16" R/W VALVE FLANGE X MJ ENDS  
GENERAL DIMENSION**

KENNEDY VALVE

MODEL KS-RW/2638

7572SS

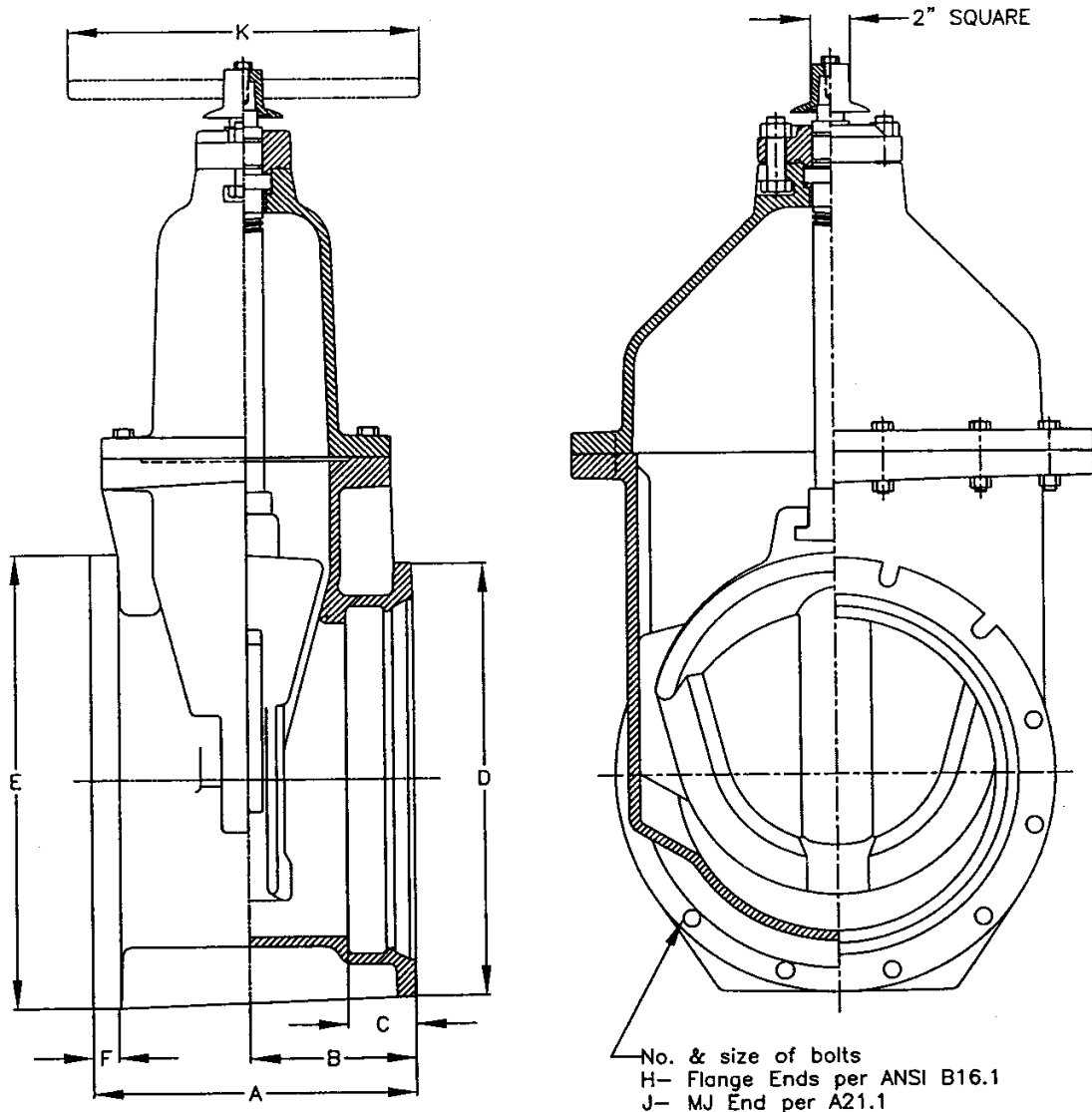

VALVE SIZE	A	B	C	D	E	F	G	H	J	K
14	17	8.5	3.5	20.25	21	1.38	37.75	12-1	10-3/4	18
16	16.5	8.5	3.5	22.5	23.5	1.50	37.75	16-1	12-3/4	18

Complies  
AWWA C515

**14"-24" R/W VALVE MJ X FLANGE END  
BEVEL GEAR GENERAL DIMENSIONS**

KENNEDY VALVE

MODEL KS-RW/2638

7572BMSS

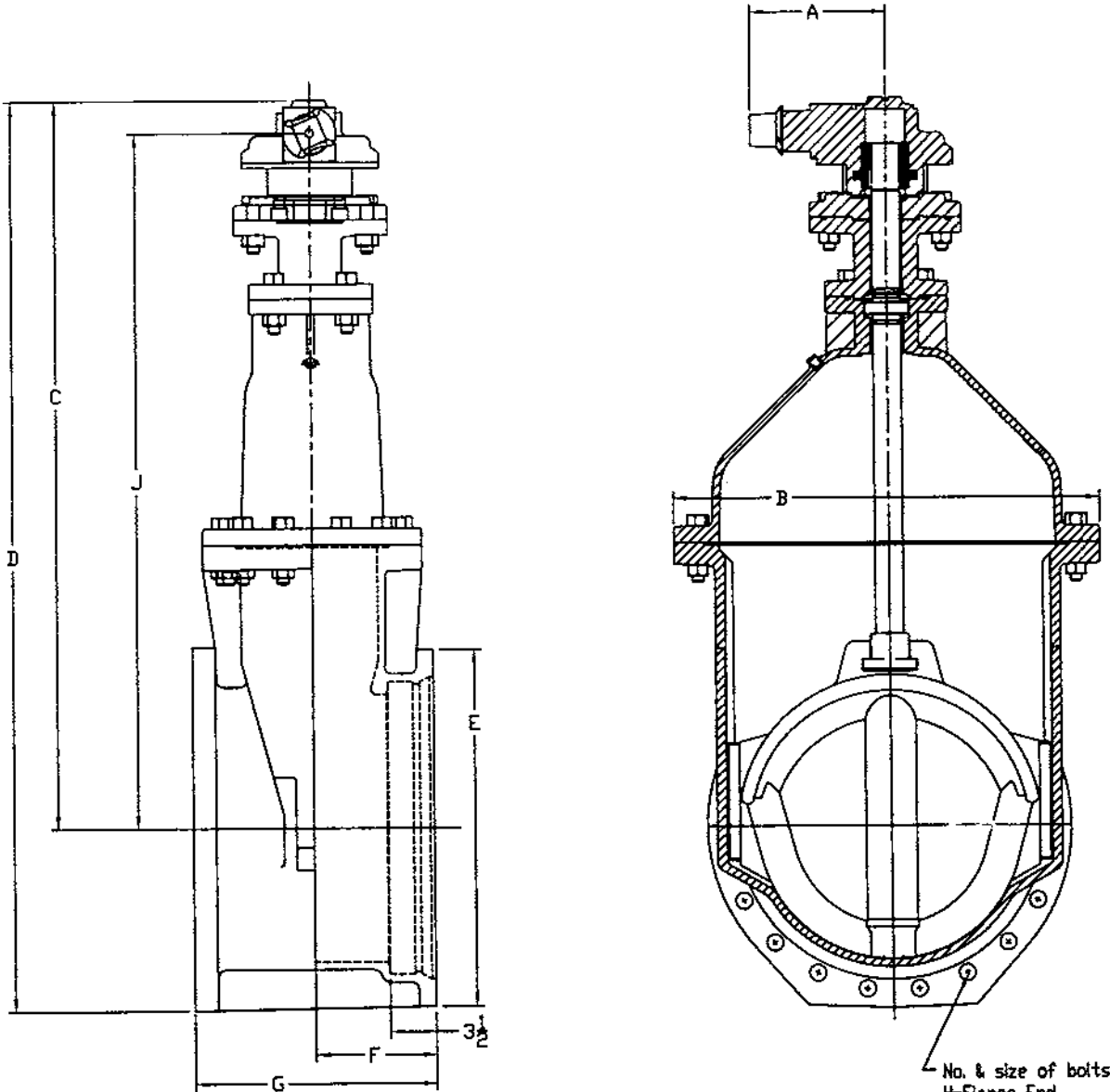

VALVE SIZE	A	B	C	D	E	F	G	H	J	K
14	9 1/8	26 11/16	48 5/8	59 1/2	20 1/4	8 1/2	17	12-1 1/8	46 3/8	10-3/4
16	9 1/8	26 11/16	47 5/8	59 1/2	22 1/2	8 1/2	16 1/2	16-1	45 3/8	12-3/4
*18	10 1/8	32 1/4	55 3/4	68 3/4	24 3/4	9 3/8	18 3/8	16-1 1/8	53 3/4	12-3/4
*20	10 1/8	32 1/4	54 3/4	68 3/4	27	9 5/32	18	20-1 1/8	52 3/4	14-3/4
**24	10 1/8	36 1/2	59 7/8	75 1/8	31 1/2	9 1/2	20 1/4	20-1 1/4	57 3/8	16-3/4

\*18" AND LARGER SIZES REQUIRE GEARING

\*\*24" ARE NOW FURNISHED WITH ROLLERS, TRACKS, AND SCRAPERS.

(see dimensions on page 6-15 for new installation)

**24" R/W RTS BEVEL GEAR MJ X  
FLANGE ENDS GENERAL DIMENSIONS**

KENNEDY VALVE

MODEL KS-RW/2638

7572BMSS

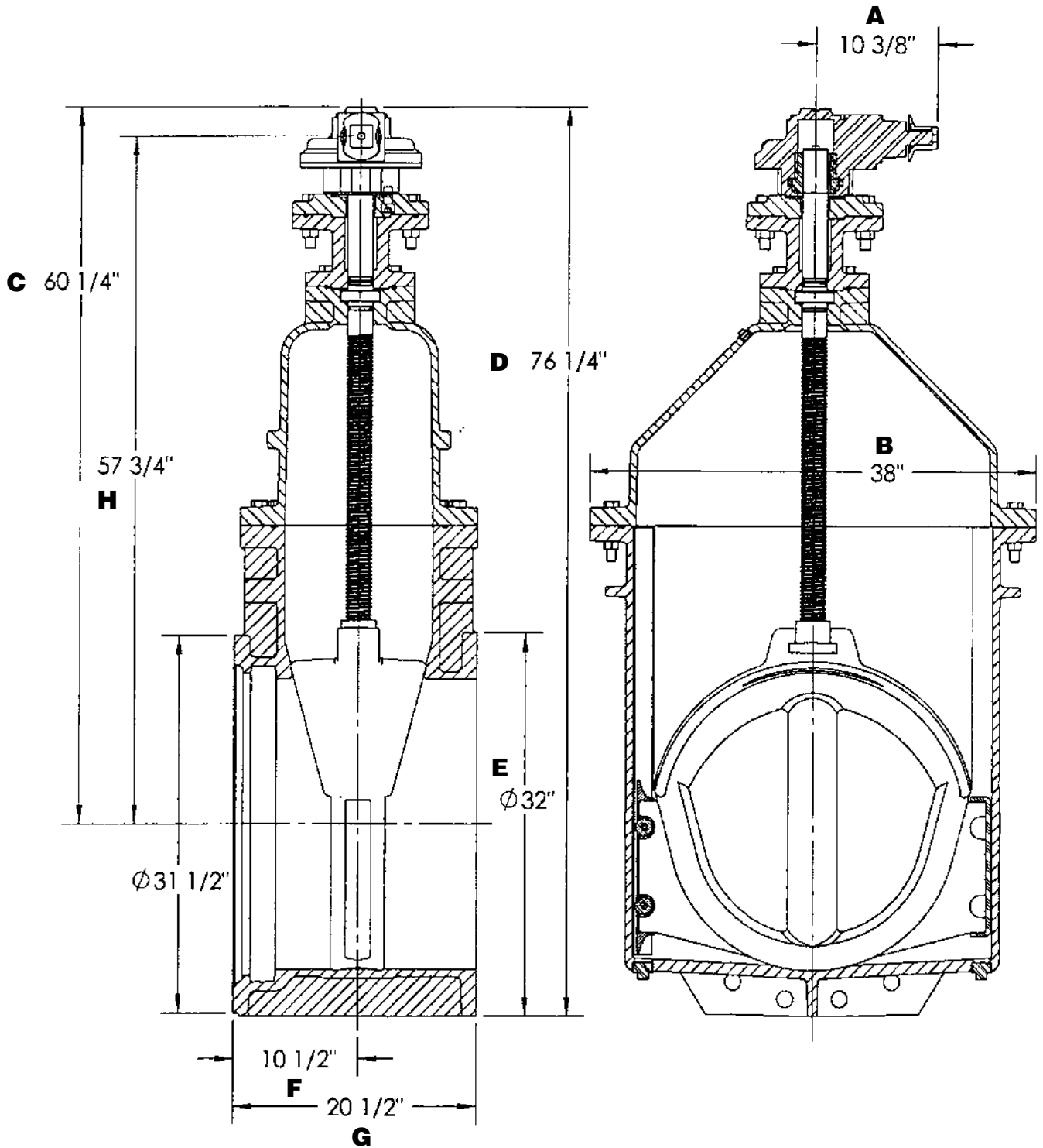

Complies with applicable requirements of AWWA C515

**14"-24" R/W VALVE MJ X FLANGE END  
SPUR GEAR GENERAL DIMENSIONS**

KENNEDY VALVE

MODEL KS-RW/2638

7572AMSS

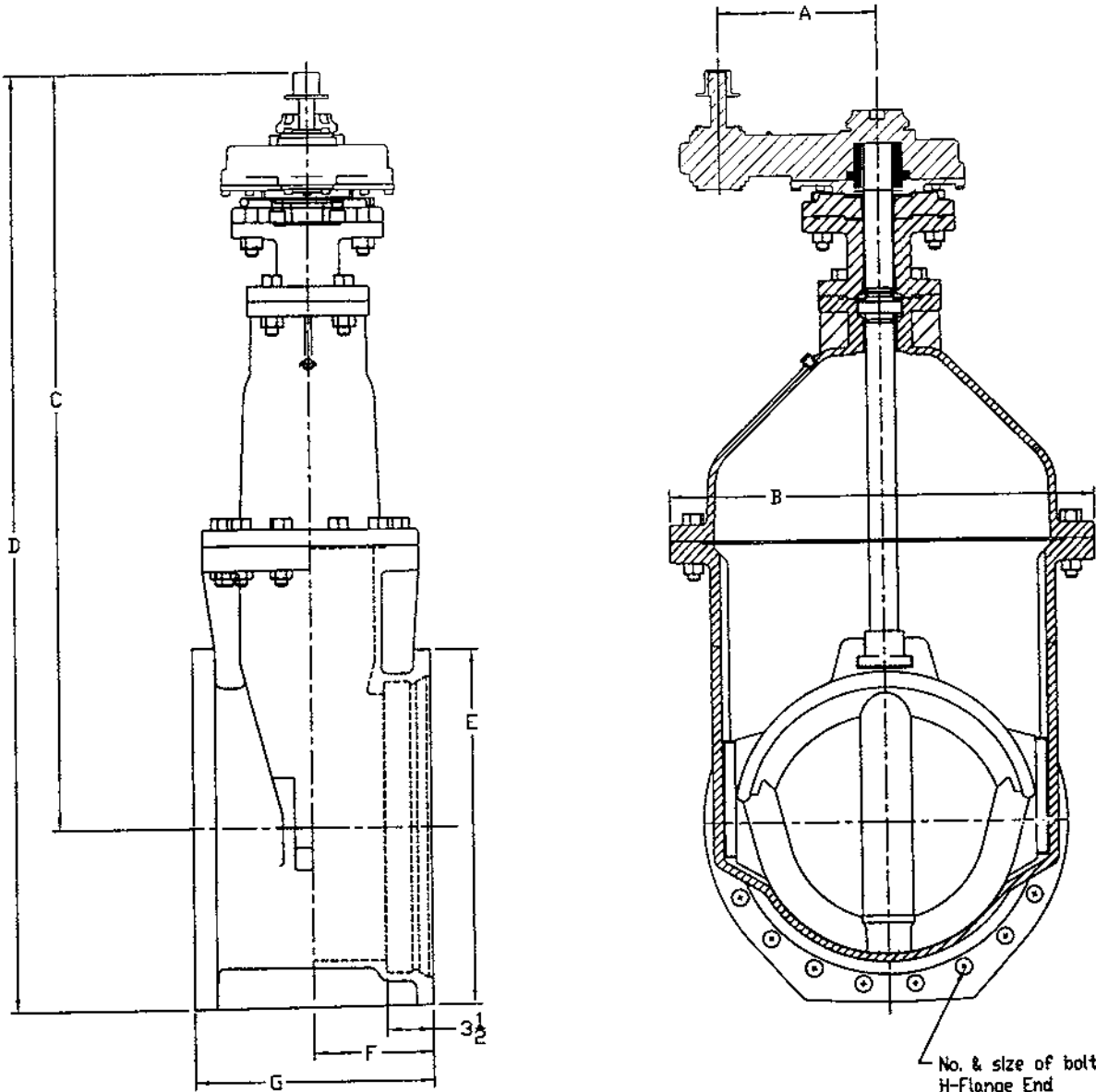

VALVE SIZE	A	B	C	D	E	F	G	H	K
14	8	26 11/16	52 1/8	62 1/2	20 1/4	8 1/2	17	12-1 1/8	10-3/4
16	8	26 11/16	51 1/8	62 1/2	22 1/2	8 1/2	16 1/2	16-1	12-3/4
*18	12	32 1/4	58	70 1/2	24 3/4	9 3/8	18 3/8	16-1 1/8	12-3/4
*20	12	32 1/4	57	70 1/2	27	9 5/32	18	20-1 1/8	14-3/4
*24	12	36 1/2	62 1/8	77 3/8	31 1/2	9 1/2	20 1/4	20-1 1/4	16-3/4

\*18" AND LARGER SIZES REQUIRE GEARING



24" R/W RTS SPUR GEAR MJ X  
FLANGE ENDS GENERAL DIMENSIONS

KENNEDY VALVE

MODEL KS-RW/2638

7572AMSS

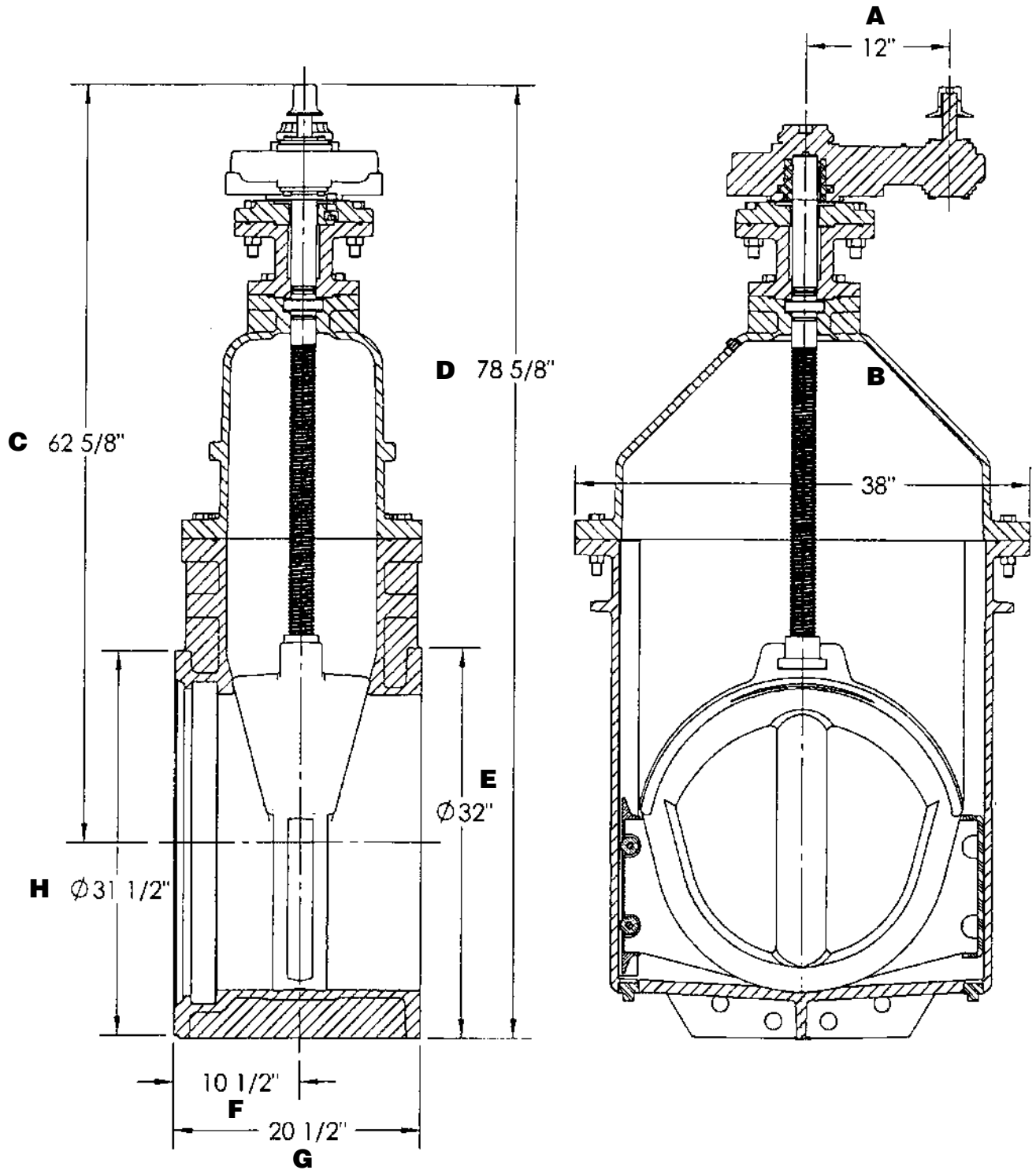

Complies with applicable requirements of AWWA C515

# 14"-16" R/W VALVE MJ TAPPING GENERAL DIMENSION

KENNEDY VALVE

MODEL KS-RW/2638

7950SS

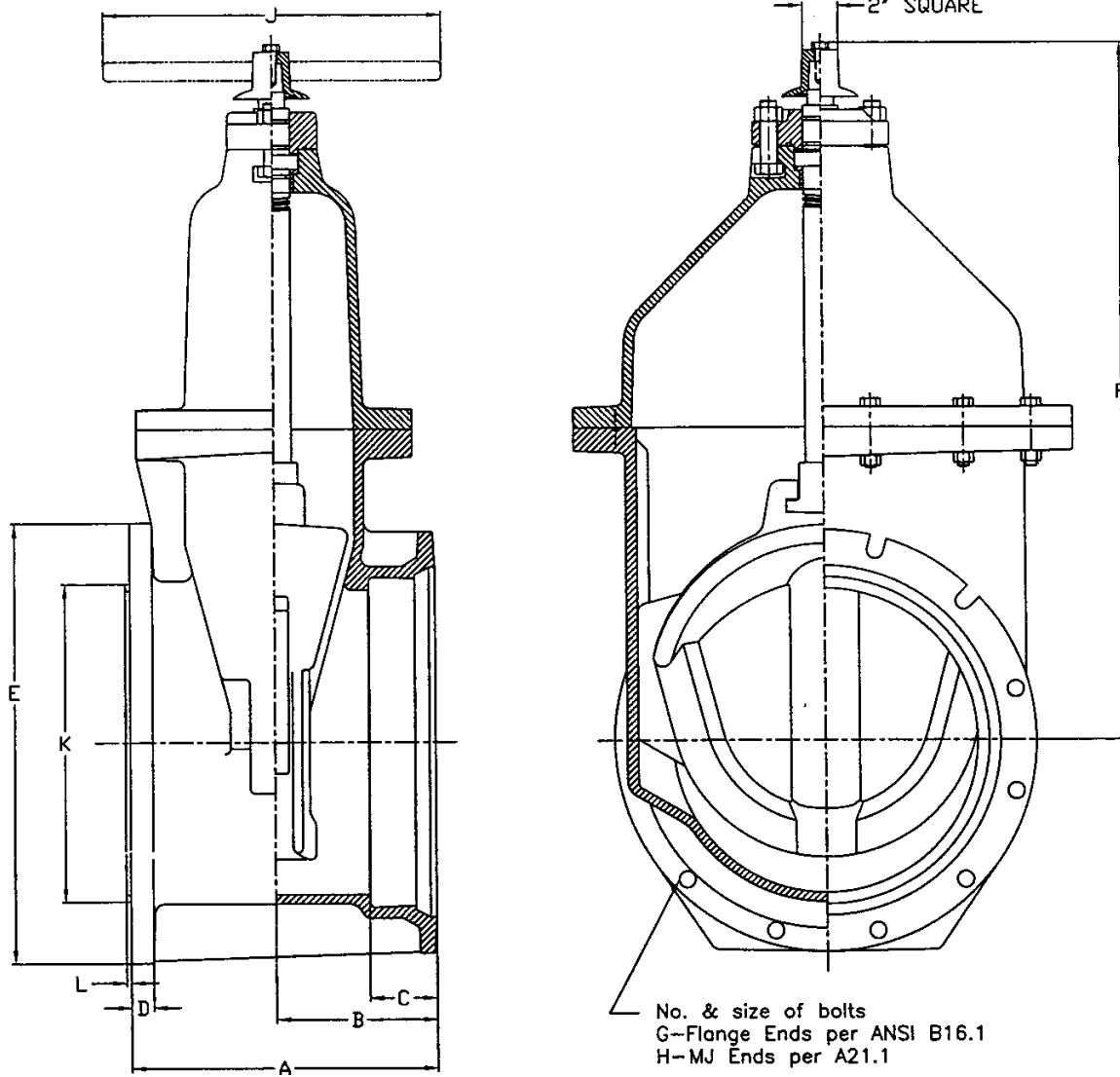

VALVE SIZE	A	B	C	D	E	F	G	H	J	K	L
14	16.75	8.5	3.5	1.18	21	37.75	21-1	10-3/4	18	14 15/16	1/4
16	16.25	8.5	3.5	1.25	23.5	37.75	16-1	12-3/4	18	16 15/16	1/4

Complies  
AWWA C515

**14"-24" R/W VALVE MJ TAP END  
BEVEL GEAR GENERAL DIMENSIONS**

KENNEDY VALVE

MODEL KS-RW/2638

7950BMSS

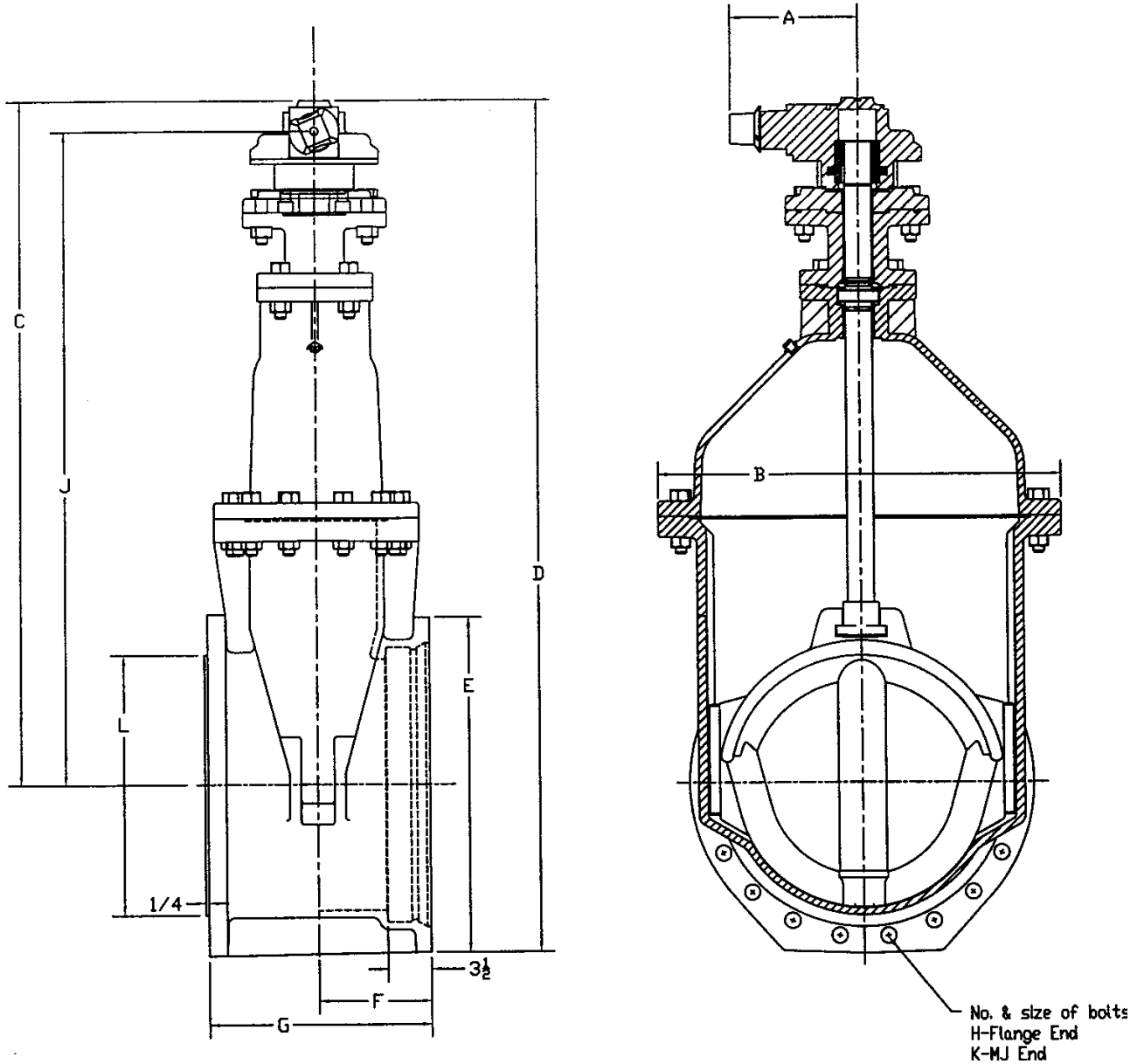

VALVE SIZE	A	B	C	D	E	F	G	H	J	K	L
14	9 1/8	26.69	48 5/8	59 1/2	20 1/4	8 1/2	16 3/4	12-1	46 3/8	10-3/4	14 15/16
16	9 1/8	26.69	47 5/8	59 1/2	22 1/2	8 1/2	17	16-1	45 3/8	12-3/4	16 15/16
*18	10 1/8	32 1/4	55 3/4	68 3/4	24 3/4	9 3/8	18 1/8	16-1 1/8	53 3/4	12-3/4	18 15/16
*20	10 1/8	32 1/4	54 3/4	68 3/4	27	9	18	20-1 1/8	52 3/4	14-3/4	20 15/16
**24	10 1/8	36 1/2	59 7/8	75 1/8	31 1/2	10 1/2	20 1/2	20-1 1/4	57 3/8	16-3/4	24 15/16

\*18" AND LARGER SIZES REQUIRE GEARING

\*\*24" ARE NOW FURNISHED WITH ROLLERS, TRACKS, AND SCRAPERS.  
(see dimensions on page 6-20 for new installation)

**24" R/W RTS BEVEL GEAR MJ X TAP  
ENDS GENERAL DIMENSIONS**

KENNEDY VALVE

MODEL KS-RW/2638

7950BMSS

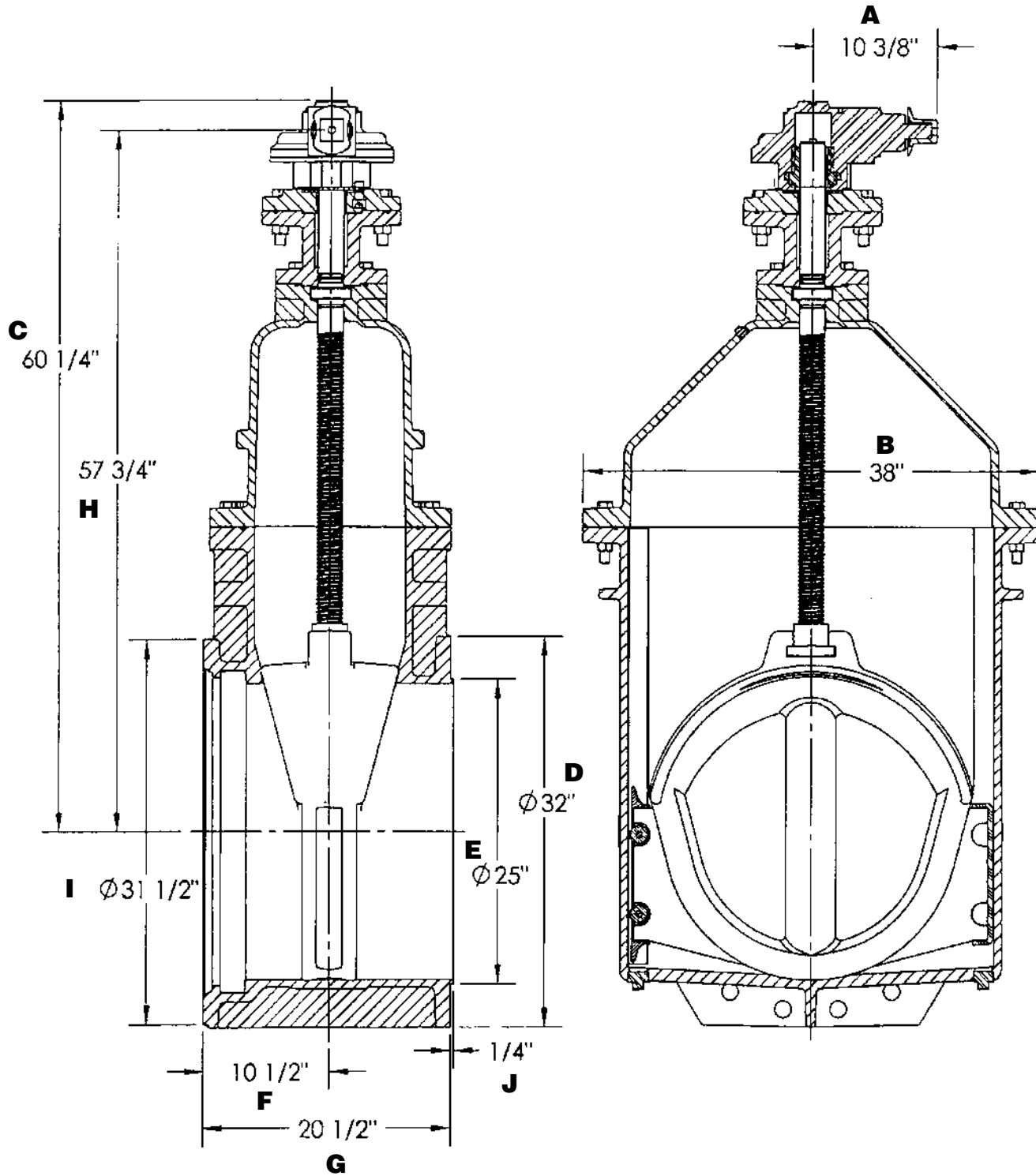

24" R/W RTS BEVEL GEAR MJ X TAP  
ENDS GENERAL DIMENSIONS

KENNEDY VALVE

MODEL KS-RW/2638

7950AMSS

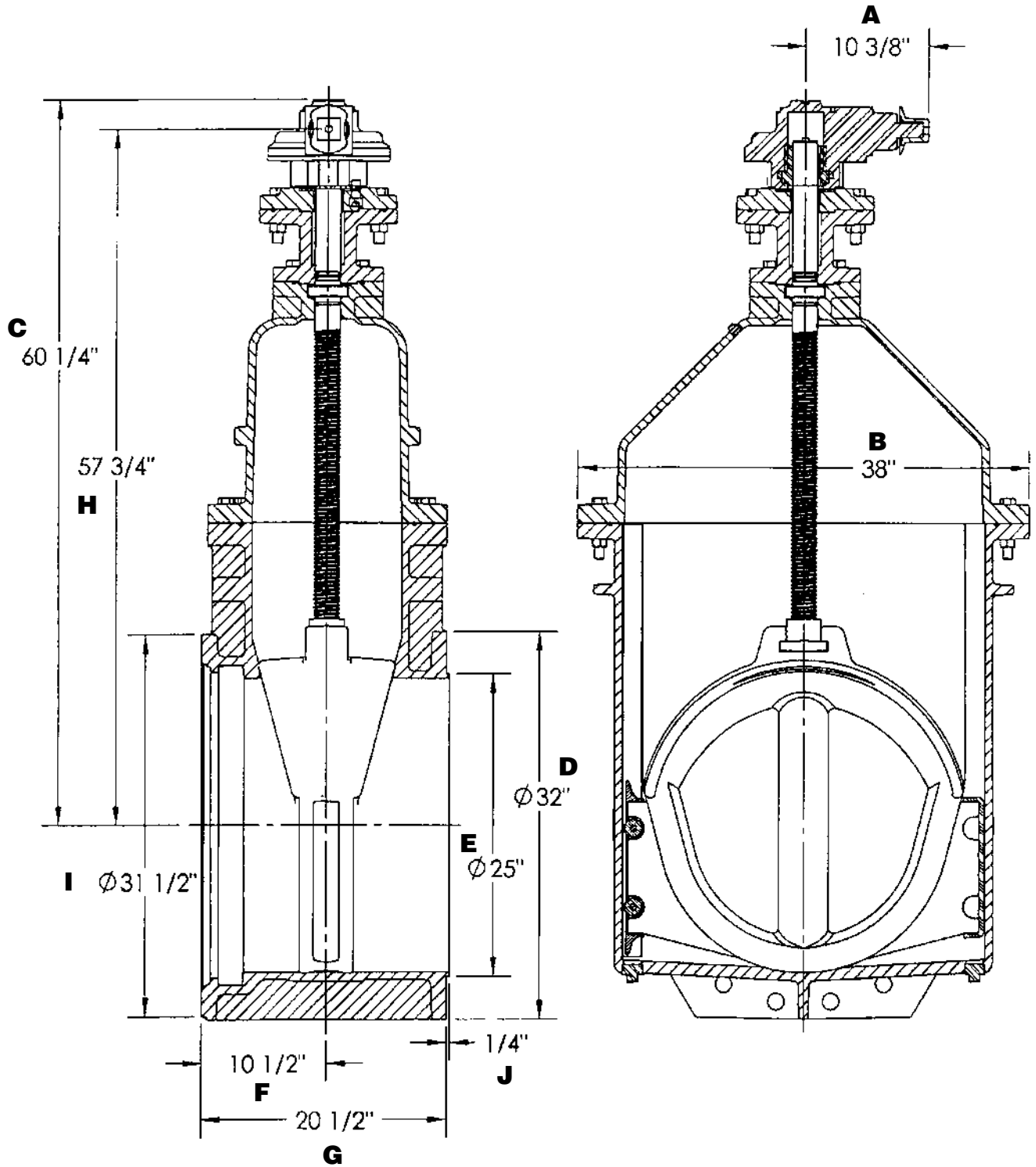

Complies  
AWWA C515

**14"-24" R/W VALVE  
BEVEL GEAR MATERIAL LIST**

KENNEDY VALVE

MODEL KS-RW/2638

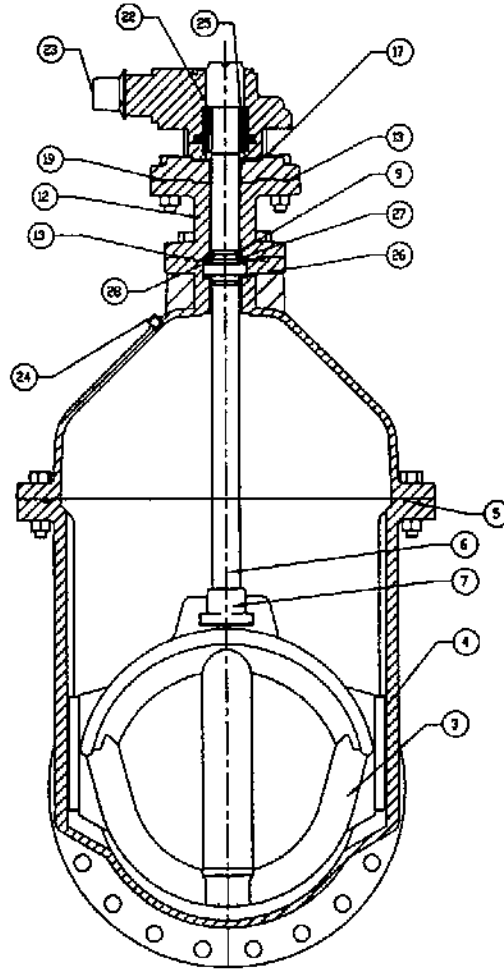
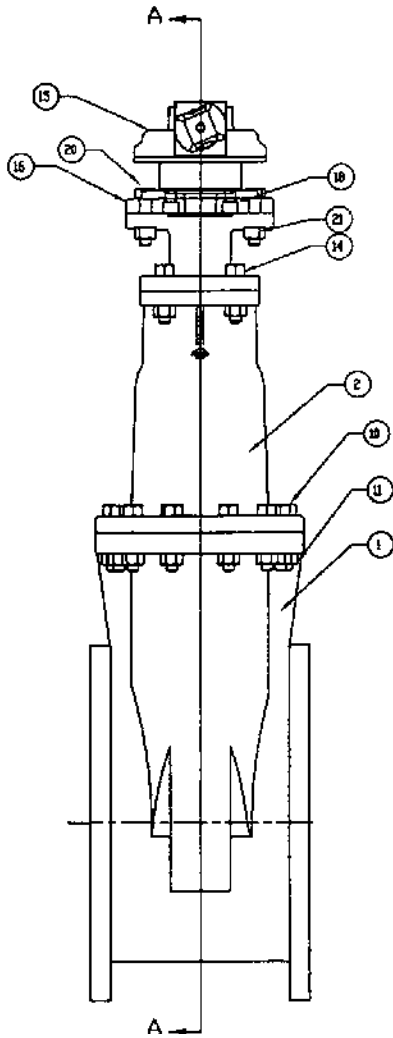

ITEM	DESCRIPTION	MATERIAL	MATERIAL SPECIFICATION
1	BODY	DUCTILE IRON	ASTM A536 64-45-12
2	COVER	DUCTILE IRON	ASTM A536 65-45-12
3	WEDGE	DUCTILE IRON/RUBBER EPDM	ASTM A536 65-45-12/EPDM
4	WEDGE CAP (18"-24" ONLY)	DELTRIN	DELTRIN
5	O-RING	RUBBER	NBR
6	STEM	BRONZE	ASTM B584 C86700
7	STEM NUT	BRONZE	ASTM B584 C86700
9	O-RING	RUBBER	NBR
10	HEX HEAD BOLT	STAINLESS STEEL	ASTM F593-304
11	HEX NUT	STAINLESS STEEL	ASTM F593-304
12	EXTENSION	DUCTILE IRON	ASTM A536 65-45-12
13	O-RING	RUBBER	NBR
14	HEX HEAD BOLT	STAINLESS STEEL	ASTM F593-304
15	ACTUATOR - 3:1 (18-24") 2:1 (14-16")		
16	ADAPTER PLATE	DUCTILE IRON	ASTM A536 65-45-12
17	ACTUATOR GASKET	RUBBER	NBR
18	SOCKET HEAD BOLT	ALLOY STEEL	ALLOY STEEL
19	O-RING	RUBBER	NBR
20	HEX BOLT	STAINLESS STEEL	ASTM F593-304
21	HEX NUT	STAINLESS STEEL	ASTM F593-304
22	KEY	STEEL	-----
23	OP NUT	DUCTILE IRON	ASTM A536 65-45-12
24	PIPE PLUG	STEEL	STEEL
25	DRIVE SLEEVE	STEEL	AISI 1023
26	COVER BUSHING	BRONZE	ASTM B584 C86700
27	EXTENSION BUSHING	BRONZE	ASTM B584 C86700
28	THRUST BEARING (18"-24" ONLY)	DELTRIN	DELTRIN

# 14" - 24" RTS BEVEL GEAR PARTS LIST

KENNEDY VALVE

MODEL KS-RW/2638

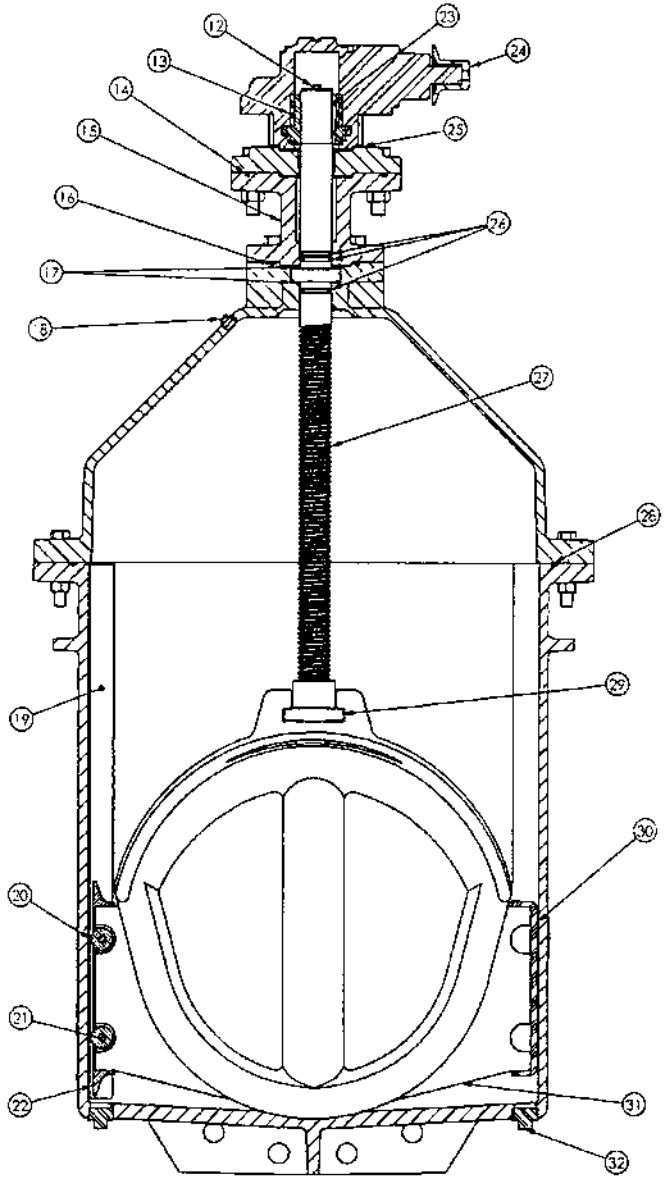
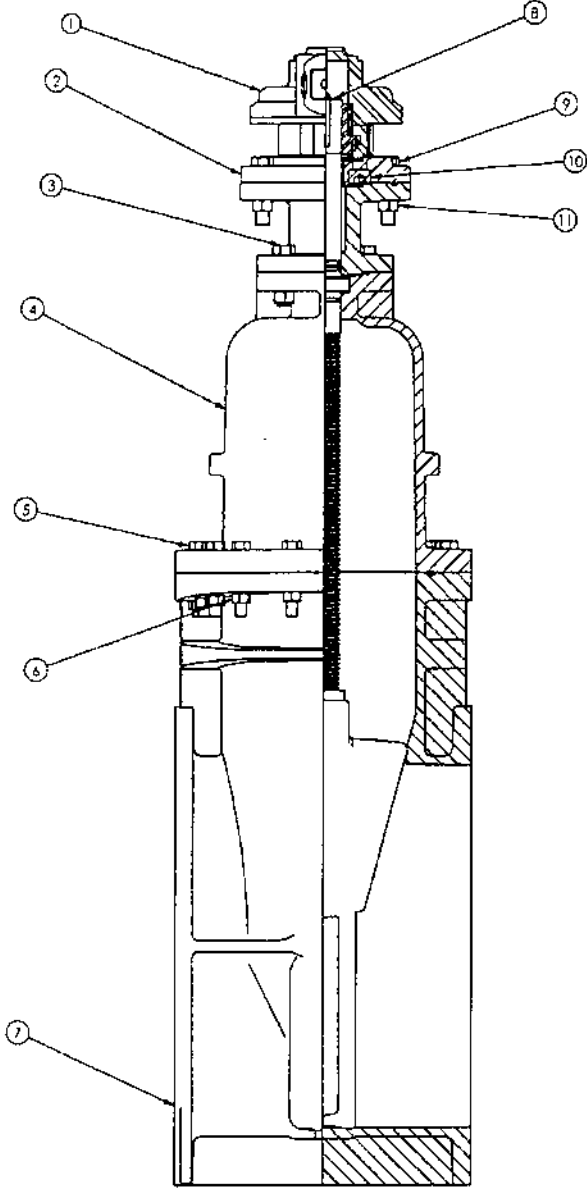

ITEM	DESCRIPTION	MATERIAL	MATERIAL SPECIFICATION	ITEM	DESCRIPTION	MATERIAL	MATERIAL SPECIFICATION
1	EXEECO IB7 3:1 ACTUATOR			18	PIPE PLUG	STAINLESS STEEL	ASTM F593-304
2	ADAPTOR PLATE	DUCTILE IRON	ASTM A 36 65-45-12	19	TRACK	STAINLESS STEEL	ASTM F593-316
3	EXTENSION BOLTS	STAINLESS STEEL	ASTM F593-304	20	ROLLER	BRONZE	ASTM B148 C954
4	COVER	DUCTILE IRON	ASTM A536 64-45-12	21	PIN	STAINLESS STEEL	AISI 303
5	COVER BOLTS	STAINLESS STEEL	ASTM F593-304	22	SCRAPER	BRONZE	ASTM B148 C954
6	HEX NUTS	STAINLESS STEEL	ASTM F593-304	23	KEY	STEEL	STEEL
7	BODY - FLANGE	DUCTILE IRON	ASTM A536 65-45-12	24	OP NUT	DUCTILE IRON	ASTM A536 65-45-12
8	WASHER	STEEL	STEEL	25	ACTUATOR GASKET	RUBBER	BUNA-N
9	ADAPTOR PLATE BOLTS	STAINLESS STEEL	ASTM F593-304	26	STEM O-RING	RUBBER	EPDM
10	SOCKET HEAD BOLTS	STAINLESS STEEL	ASTM F593-304	27	STEM	BRONZE	ASTM B583 C86700
11	HEX NUTS	STAINLESS STEEL	ASTM F593-304	28	COVER O-RING	RUBBER	EPDM
12	HOLD DOWN BOLT	STAINLESS STEEL	ASTM F593-304	29	STEM NUT	BRASS	ASTM B584 C83600
13	DRIVE SLEEVE	STEEL	AISI 1023	30	PROTECTOR	DELTRIN	DELTRIN
14	ADAPTOR O-RING	RUBBER	EPDM	31	WEDGE	DUCTILE IRON/RUBBER	ASTM A536 65-45-12
15	EXTENSION	DUCTILE IRON	ASTM A536 65-45-12	32	PIPE PLUG	STAINLESS STEEL	ASTM F593-304
16	EXTENSION O-RING	RUBBER	EPDM				
17	THRUST WASHER	DETRIN	DETRIN				

Complies  
AWWA C515

**14"-24" R/W VALVE  
SPUR GEAR MATERIAL LIST**

KENNEDY VALVE

MODEL KS-RW/2638

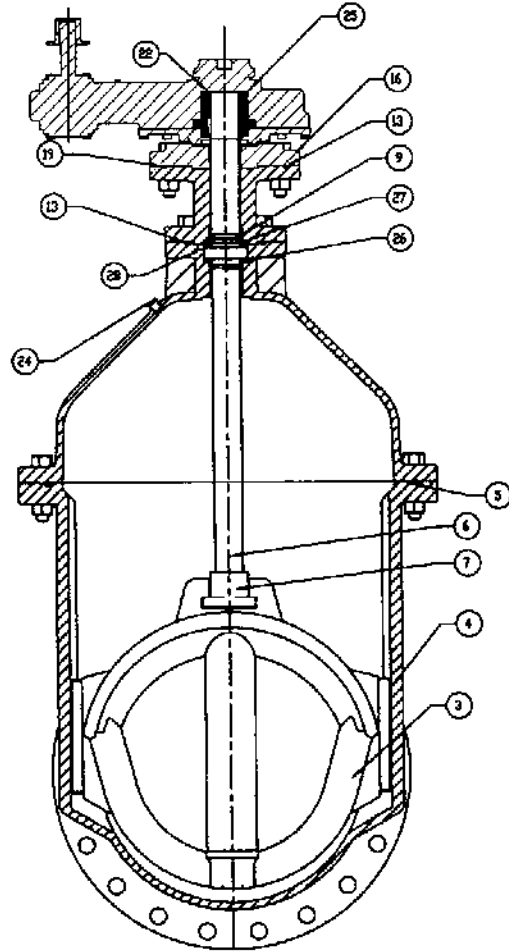
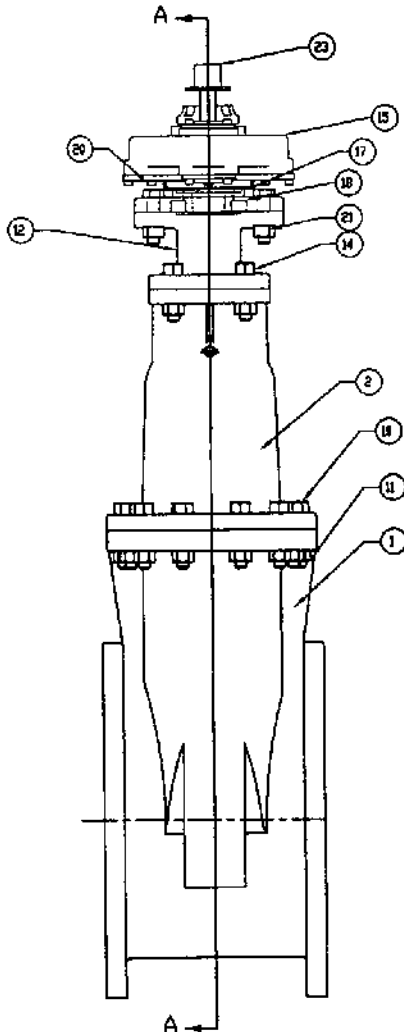

ITEM	DESCRIPTION	MATERIAL	MATERIAL SPECIFICATION
1	BODY	DUCTILE IRON	ASTM A536 64-45-12
2	COVER	DUCTILE IRON	ASTM A536 65-45-12
3	WEDGE	DUCTILE IRON/RUBBER EPDM	ASTM A536 65-45-12/EPDM
4	WEDGE CAP (18"-24" ONLY)	DELTRIN	DELTRIN
5	O-RING	RUBBER	NBR
6	STEM	BRONZE	ASTM B584 C86700
7	STEM NUT	BRONZE	ASTM B584 C86700
9	O-RING	RUBBER	NBR
10	HEX HEAD BOLT	STAINLESS STEEL	ASTM F593-304
11	HEX NUT	STAINLESS STEEL	ASTM F593-304
12	EXTENSION	DUCTILE IRON	ASTM A536 65-45-12
13	O-RING	RUBBER	NBR
14	HEX HEAD BOLT	STAINLESS STEEL	ASTM F593-304
15	ACTUATOR - 3:1 (18"-24") 2:1 (14"-16")		
16	ADAPTER PLATE	DUCTILE IRON	ASTM A536 65-45-12
17	ACTUATOR GASKET	RUBBER	NBR
18	SOCKET HEAD BOLT	ALLOY STEEL	ALLOY STEEL
19	O-RING	RUBBER	NBR
20	HEX BOLT	STAINLESS STEEL	ASTM F593-304
21	HEX NUT	STAINLESS STEEL	ASTM F593-304
22	KEY	STEEL	-----
23	OP NUT	DUCTILE IRON	ASTM A536 65-45-12
24	PIPE PLUG	STEEL	STEEL
25	DRIVE SLEEVE	STEEL	AISI 1023
26	COVER BUSHING	BRONZE	ASTM B584 C86700
27	EXTENSION BUSHING	BRONZE	ASTM B584 C86700
28	THRUST BEARING (18"-24" ONLY)	DELTRIN	DELTRIN



# 14" - 24" RTS SPUR GEAR PARTS LIST

KENNEDY VALVE

MODEL KS-RW/2638

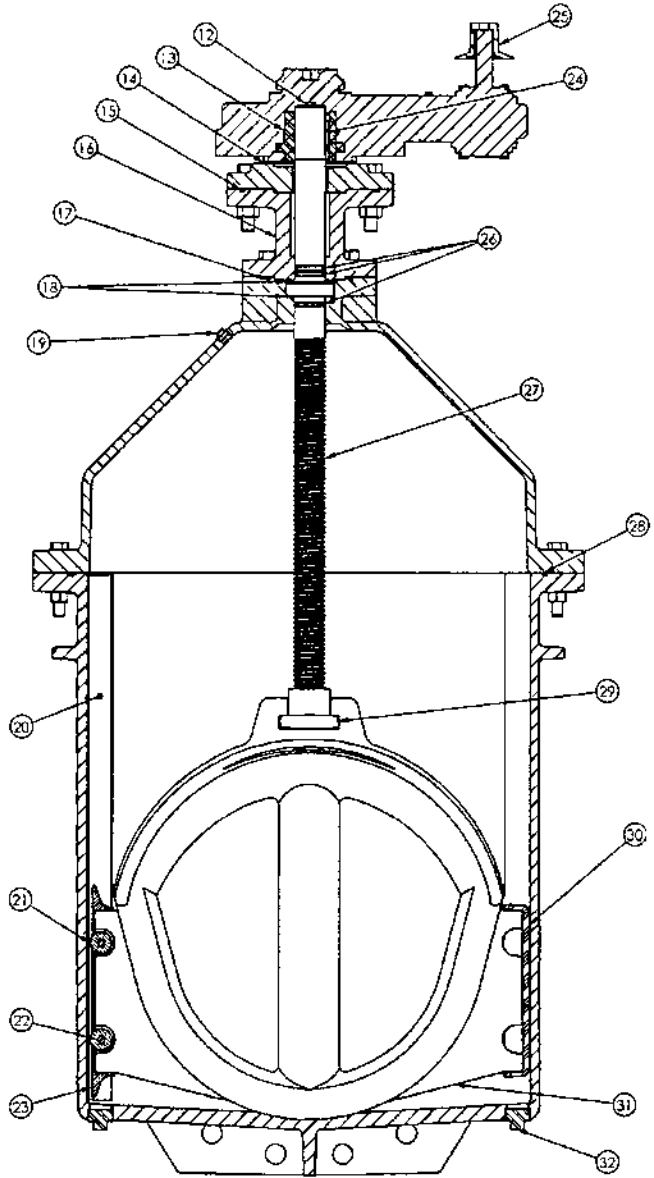
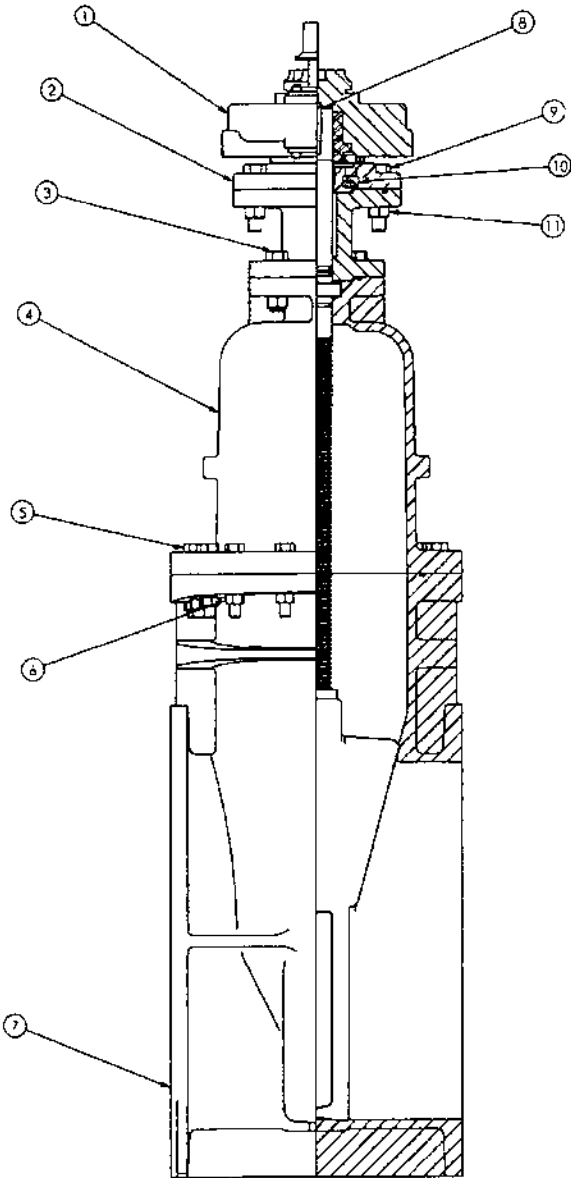

ITEM	DESCRIPTION	MATERIAL	MATERIAL SPECIFICATION	ITEM	DESCRIPTION	MATERIAL	MATERIAL SPECIFICATION
1	EXEECO IB7 3:1 ACTUATOR			18	THRUST WASHER	DETRIN	DETRIN
2	ADAPTOR PLATE	DUCTILE IRON	ASTM A 36 65-45-12	19	PIPE PLUG	STAINLESS STEEL	ASTM F593-304
3	EXTENSION BOLTS	STAINLESS STEEL	ASTM F593-304	20	TRACK	STAINLESS STEEL	ASTM F593-316
4	COVER	DUCTILE IRON	ASTM A536 64-45-12	21	ROLLER	BRONZE	ASTM B148 C954
5	COVER BOLTS	STAINLESS STEEL	ASTM F593-304	22	PIN	STAINLESS STEEL	AISI 303
6	HEX NUTS	STAINLESS STEEL	ASTM F593-304	23	SCRAPER	BRONZE	ASTM B148 C954
7	BODY - FLANGE	DUCTILE IRON	ASTM A536 65-45-12	24	KEY	STEEL	STEEL
8	WASHER	STEEL	STEEL	25	OP NUT	DUCTILE IRON	ASTM A536 65-45-12
9	ADAPTOR PLATE BOLTS	STAINLESS STEEL	ASTM F593-304	26	STEM O-RING	RUBBER	EPDM
10	SOCKET HEAD BOLTS	STAINLESS STEEL	ASTM F593-304	27	STEM	BRONZE	ASTM B583 C86700
11	HEX NUTS	STAINLESS STEEL	ASTM F593-304	28	COVER O-RING	RUBBER	EPDM
12	HOLD DOWN BOLT	STAINLESS STEEL	ASTM F593-304	29	STEM NUT	BRASS	ASTM B584 C83600
13	DRIVE SLEEVE	STEEL	AISI 1023	30	PROTECTOR	DELTRIN	DELTRIN
14	ACTUATOR GASKET	RUBBER	BUNA-N	31	WEDGE	DUCTILE IRON/RUBBER	ASTM A536 65-45-12
15	ADAPTOR O-RING	RUBBER	EPDM	32	PIPE PLUG	STAINLESS STEEL	ASTM F593-304
16	EXTENSION	DUCTILE IRON	ASTM A536 65-45-12				
17	EXTENSION O-RING	RUBBER	EPDM				

Complies with  
AWWA C515

**16" R/W VALVE TYTON ENDS  
NRS GENERAL DIMENSIONS**

KENNEDY VALVE

MODEL KS-RW/2638

7901SS

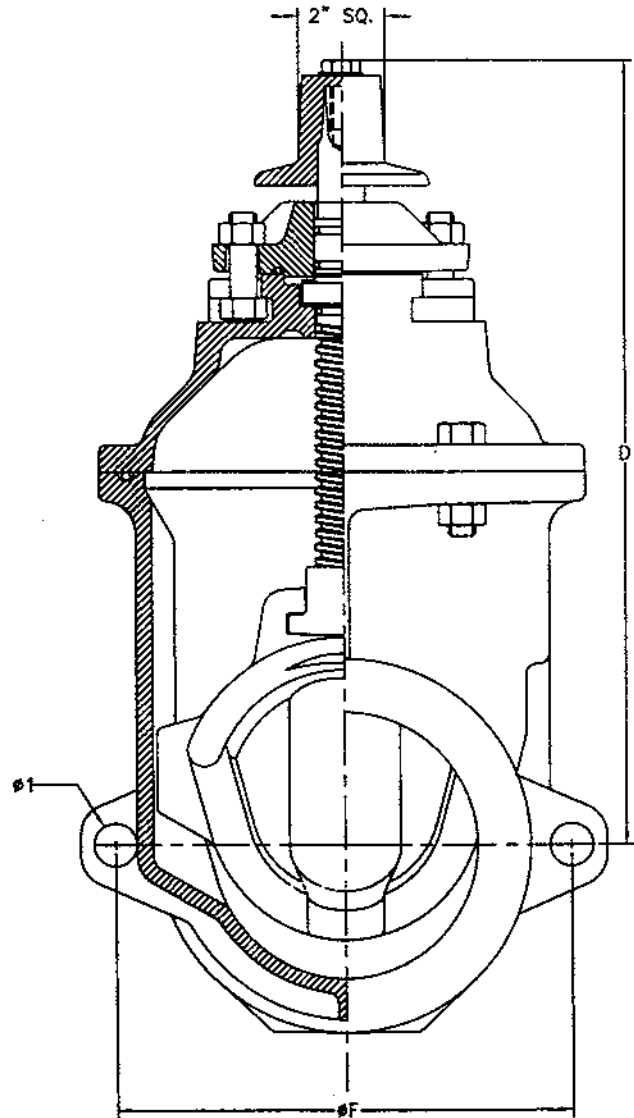
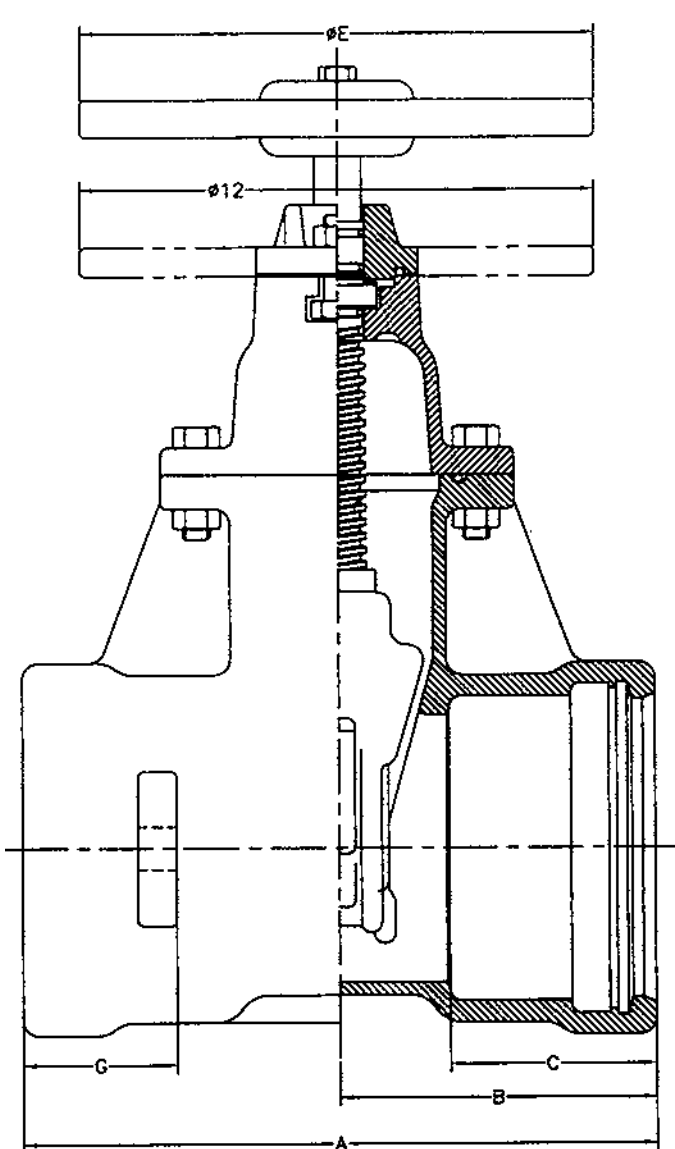

VALVE SIZE	A	B	C	D	E	F	G
16	20 1/2	10 1/4	5	50	26	22.46	1 1/2

Complies with applicable requirements of AWWA C515

**14"-16" R/W VALVE OS&Y MATERIAL LIST**

KENNEDY VALVE

MODEL KS-RW/2638

7566

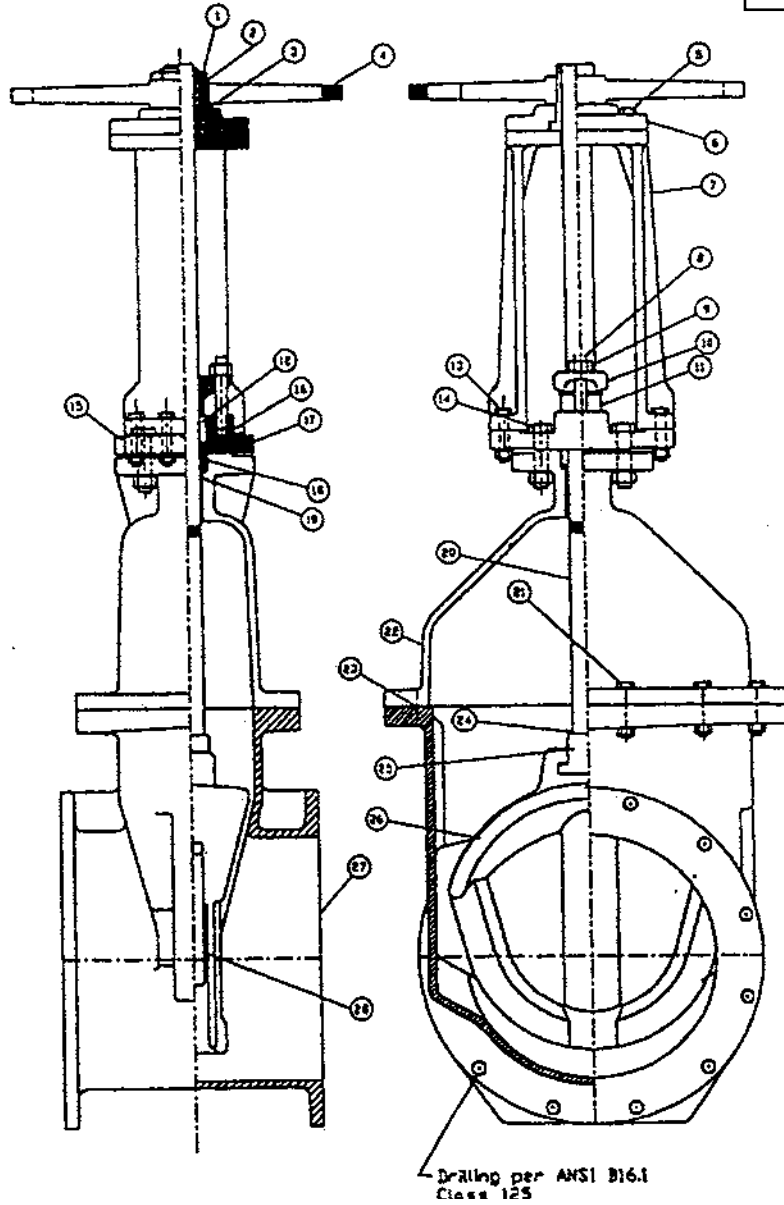

ITEM	NAME OF PART	MATERIAL	ITEM	NAME OF PART	MATERIAL
1	HOLD DOWN KEY	BRONZE	15	STUFFING BOX	CAST IRON
2	KEY	STEEL	16	BUSHING-UPPER	BRONZE
3	TOP STEM NUT	BRONZE	17	GASKET	ACORAC
4	HANDWHEEL	CAST IRON	18	SPACER	BRONZE
5	CAPSCREW	ZINC PLATED STEEL	19	BUSHING-LOWER	BRONZE
6	ADAPTER	CAST IRON	20	STEM	BRONZE
7	YOKE	CAST IRON	21	CAPSCREW & NUT	ZINC PLATED STEEL
8	STUD	ZINC PLATED STEEL	22	COVER	DUCTILE IRON
9	HEX NUT	BRONZE	23	O-RING-COVER	BUNA-N
10	FOLLOWER	CAST IRON	24	O-RING-STEM	BUNA-N
11	GLAND	BRONZE	25	STEM NUT	BRONZE
12	PACKING	BRAIDED POLYMER	26	WEDGE	DUCTILE IRON/EPDM
13	CAPSCREW & NUT	ZINC PLATED STEEL	27	BODY	DUCTILE IRON
14	CAPSCREW & NUT	ZINC PLATED STEEL	28	WEDGE CAP	DELTRIN

Complies with applicable requirements of AWWA C515

**14"-16" R/W VALVE OS&Y**

KENNEDY VALVE

MODEL KS-RW/2638

7566

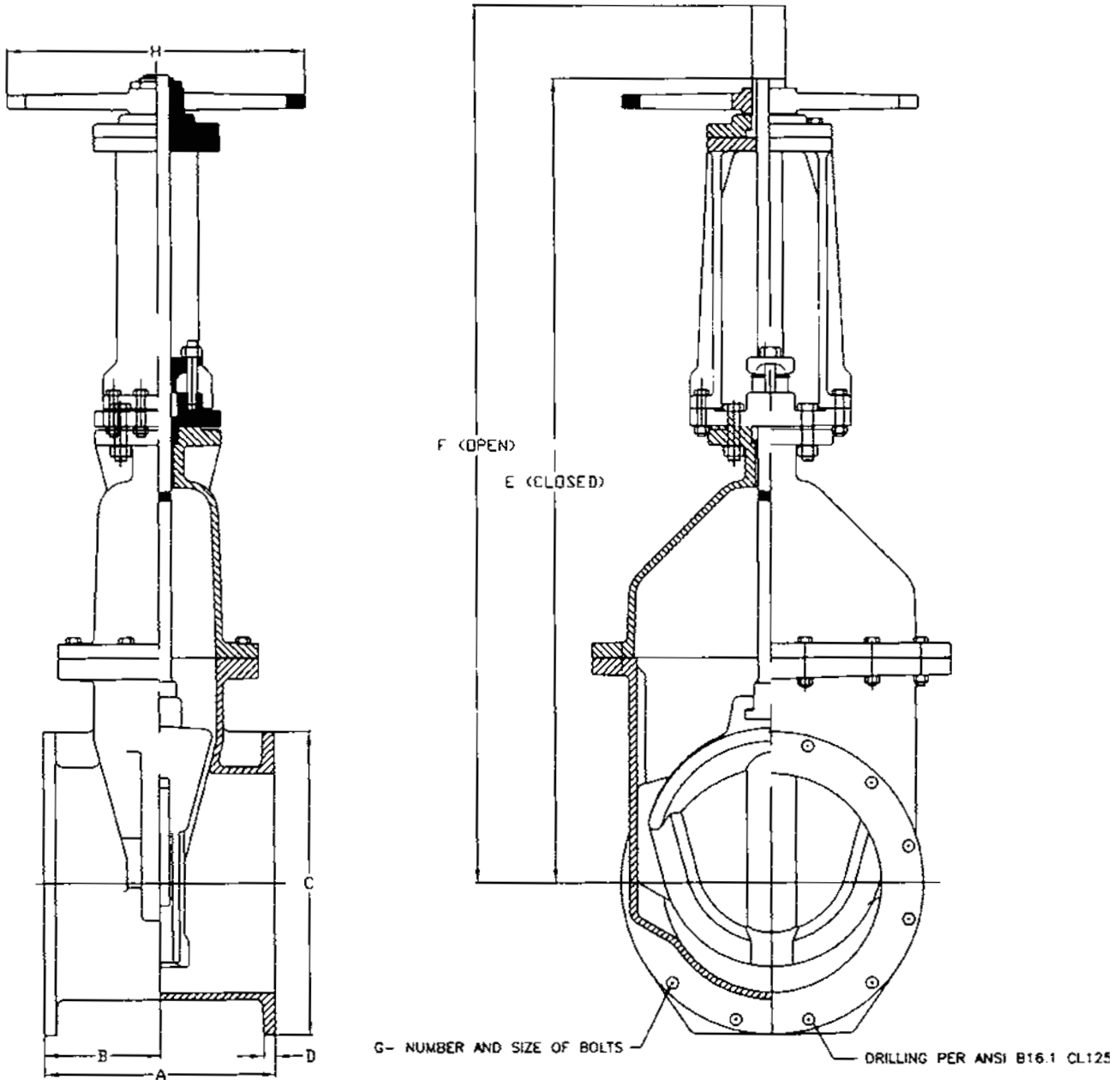

VALVE SIZE	A	B	C	D	E	F	G	H
14	15	7 1/2	21	1 3/8	59 3/4	74 3/4	12-1	22
16	16	8	23 1/2	1 7/16	59 3/4	74 3/4	16-1	22

Complies with applicable requirements of AWWA C515

**14"-24" R/W OS&Y WITH SPUR GEAR ACTUATOR**

KENNEDY VALVE

MODEL KS-RW/2638

7566AM

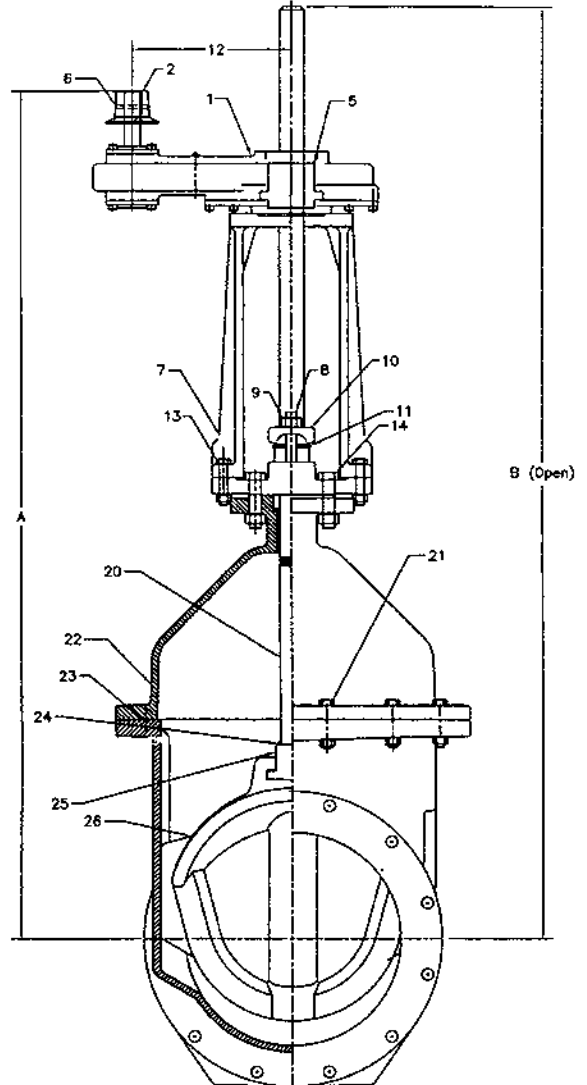
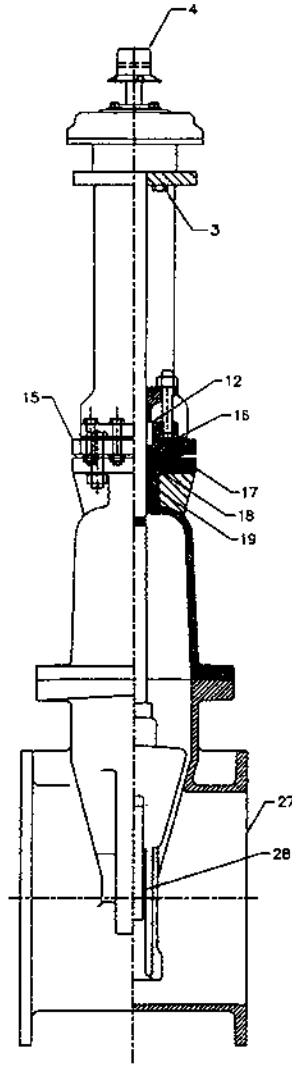

ITEM	DESCRIPTION	
1	EXEECO IS7	BRONZE ASTM B584 C83600
2	SQUARE KEY	COMMERCIAL STEEL
3	HEX CAPSCREW	ZINC PLATED STEEL ASTM A307 GR. B
4	OP NUT	GRAY IRON ASTM A126 CLASS B
5	OUTPUT SLEEVE	ALUMINUM BRONZE ASTM B505 C95800
6	ROLL PIN	STAINLESS STEEL
7	YOKE	GRAY IRON ASTM A126 CLASS B
8	STUD	BRONZE ASTM B584 C83600
9	HEX NUT	BRONZE ASTM B584 C83600
10	FOLLOWER	GRAY IRON ASTM A126 CLASS B
11	GLAND	BRONZE ASTM B584 C83600
12	PACKING	SQUARE BRAIDED FIBRE
13	CAPSCREW & HEX NUT	ZINC PLATED STEEL ASTM A307 GR. B
14	CAPSCREW & NUT	ZINC PLATED STEEL ASTM A307 GR. B
15	ADAPTER	GRAY IRON ASTM A126 CLASS B
16	BUSHING	BRONZE ASTM B584 C83600
17	FOLLOWER GASKET	FIBRE
18	COVER SPACER	BRONZE ASTM B584 C83600
19	COVER BUSHING	BRONZE ASTM B584 C83600
20	STEM & BOTTOM NUT	BRONZE ASTM B16 ALLOY 306
21	HEX CAPSCREW & HEX NUT	ZINC PLATED STEEL ASTM A307 GR. B
22	COVER	DUCTILE IRON ASTM A536 GRADE 65-45-12
23	COVER O-RING	BUNA-N
24	STEM O-RING	BUNA-N
25	STEM NUT	BRONZE ASTM B584 C83600
26	WEDGE	GRAY IRON ASTM A126 CLASS B & EPDM
27	BODY-FLANGED TYPE	DUCTILE IRON ASTM A536 GRADE 65-45-12
28	WEDGE PROTECTOR CAP	DELTRIN

	14"	16"	18"	20"	24"
A	64-1/2	64-1/2	74-5/8	74-5/8	83-1/2
B	76	76	90-7/8	90-7/8	103-5/8

Complies with applicable requirements of AWWA C515

# 14"-24" R/W OS&Y WITH BEVEL GEAR ACTUATOR

KENNEDY VALVE

MODEL KS-RW/2638

7566BM

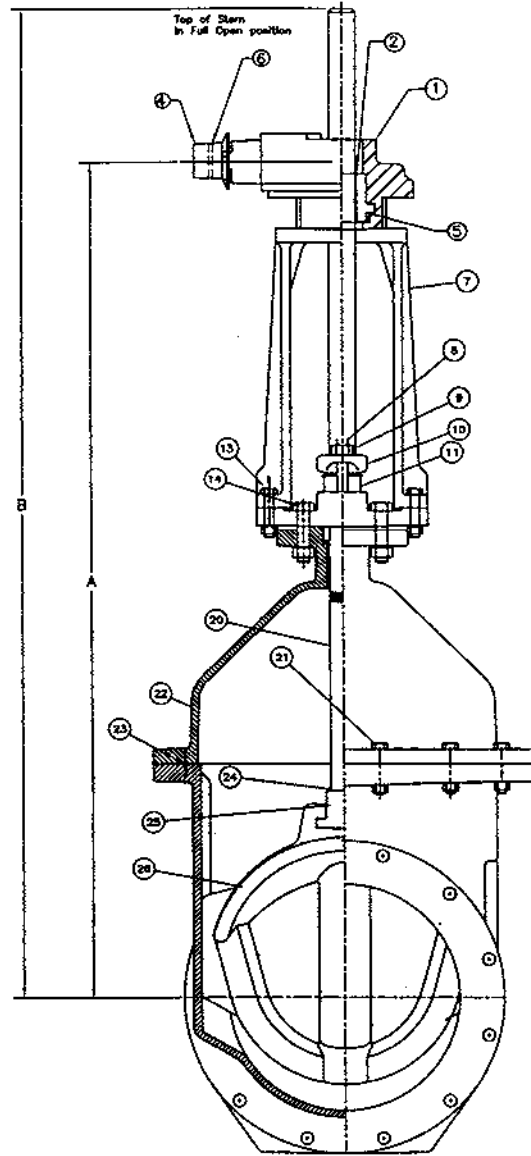
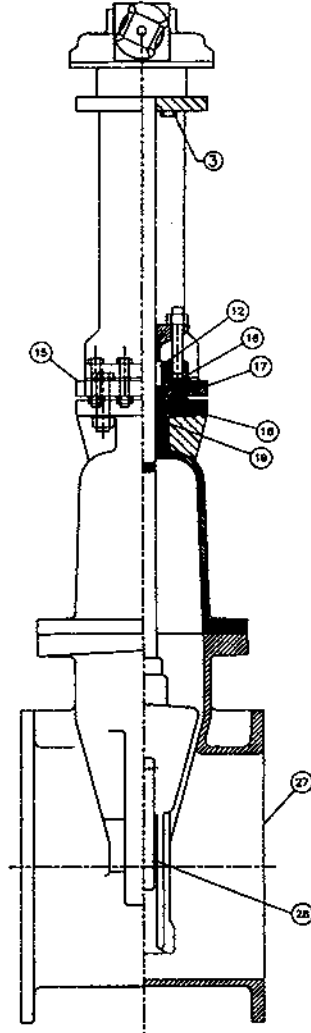

ITEM	DESCRIPTION	
1	EXEECO IB7	BRONZE ASTM B584 C83600
2	SQUARE KEY	COMMERCIAL STEEL
3	HEX CAPSCREW	ZINC PLATED STEEL ASTM A307 GR. B
4	OP NUT	GRAY IRON ASTM A126 CLASS B
5	OUTPUT SLEEVE	ALUMINUM BRONZE ASTM B505 C95800
6	ROLL PIN	STAINLESS STEEL
7	YOKE	GRAY IRON ASTM A126 CLASS B
8	STUD	BRONZE ASTM B584 C83600
9	HEX NUT	BRONZE ASTM B584 C83600
10	FOLLOWER	GRAY IRON ASTM A126 CLASS B
11	GLAND	BRONZE ASTM B584 C83600
12	PACKING	SQUARE BRAIDED FIBRE
13	CAPSCREW & HEX NUT	ZINC PLATED STEEL ASTM A307 GR. B
14	CAPSCREW & NUT	ZINC PLATED STEEL ASTM A307 GR. B
15	ADAPTER	GRAY IRON ASTM A126 CLASS B
16	BUSHING	BRONZE ASTM B584 C83600
17	FOLLOWER GASKET	FIBRE
18	COVER SPACER	BRONZE ASTM B584 C83600
19	COVER BUSHING	BRONZE ASTM B584 C83600
20	STEM & BOTTOM NUT	BRONZE ASTM B16 ALLOY 306
21	HEX CAPSCREW & HEX NUT	ZINC PLATED STEEL ASTM A307 GR. B
22	COVER	DUCTILE IRON ASTM A536 GRADE 65-45-12
23	COVER O-RING	BUNA-N
24	STEM O-RING	BUNA-N
25	STEM NUT	BRONZE ASTM B584 C83600
26	WEDGE	GRAY IRON ASTM A126 CLASS B & EPDM
27	BODY-FLANGED TYPE	DUCTILE IRON ASTM A536 GRADE 65-45-12
28	WEDGE PROTECTOR CAP	DELFIN

	14"	16"	18"	20"	24"
A	59-7/8	59-7/8	70-1/8	70-1/8	78-7/8
B	76	76	90-7/8	90-7/8	103-5/8